

This article was downloaded by: [Universite Paul Sabatier]

On: 18 February 2014, At: 04:59

Publisher: Taylor & Francis

Informa Ltd Registered in England and Wales Registered Number: 1072954 Registered office: Mortimer House, 37-41 Mortimer Street, London W1T 3JH, UK



## Numerical Functional Analysis and Optimization

Publication details, including instructions for authors and subscription information:

<http://www.tandfonline.com/loi/Infa20>

### Stokes' System in a Domain with Oscillating Boundary: Homogenization and Error Analysis of an Interior Optimal Control Problem

A. K. Nandakumaran<sup>a</sup>, Ravi Prakash<sup>a</sup> & J.-P. Raymond<sup>b</sup>

<sup>a</sup> Department of Mathematics, Indian Institute of Science, Bangalore, India

<sup>b</sup> Institut de Mathématiques de Toulouse, Université Paul Sabatier & CNRS, Toulouse Cedex, France

Accepted author version posted online: 21 Jun 2013. Published online: 06 Feb 2014.

To cite this article: A. K. Nandakumaran, Ravi Prakash & J.-P. Raymond (2014) Stokes' System in a Domain with Oscillating Boundary: Homogenization and Error Analysis of an Interior Optimal Control Problem, Numerical Functional Analysis and Optimization, 35:3, 323-355, DOI: [10.1080/01630563.2013.812657](https://doi.org/10.1080/01630563.2013.812657)

To link to this article: <http://dx.doi.org/10.1080/01630563.2013.812657>

PLEASE SCROLL DOWN FOR ARTICLE

Taylor & Francis makes every effort to ensure the accuracy of all the information (the "Content") contained in the publications on our platform. However, Taylor & Francis, our agents, and our licensors make no representations or warranties whatsoever as to the accuracy, completeness, or suitability for any purpose of the Content. Any opinions and views expressed in this publication are the opinions and views of the authors, and are not the views of or endorsed by Taylor & Francis. The accuracy of the Content should not be relied upon and should be independently verified with primary sources of information. Taylor and Francis shall not be liable for any losses, actions, claims, proceedings, demands, costs, expenses, damages, and other liabilities whatsoever or howsoever caused arising directly or indirectly in connection with, in relation to or arising out of the use of the Content.

This article may be used for research, teaching, and private study purposes. Any substantial or systematic reproduction, redistribution, reselling, loan, sub-licensing, systematic supply, or distribution in any form to anyone is expressly forbidden. Terms & Conditions of access and use can be found at <http://www.tandfonline.com/page/terms-and-conditions>

## STOKES' SYSTEM IN A DOMAIN WITH OSCILLATING BOUNDARY: HOMOGENIZATION AND ERROR ANALYSIS OF AN INTERIOR OPTIMAL CONTROL PROBLEM

A. K. Nandakumaran,<sup>1</sup> Ravi Prakash,<sup>1</sup> and J.-P. Raymond<sup>2</sup>

<sup>1</sup>Department of Mathematics, Indian Institute of Science, Bangalore, India

<sup>2</sup>Institut de Mathématiques de Toulouse, Université Paul Sabatier & CNRS,  
Toulouse Cedex, France

□ *Homogenization and error analysis of an optimal interior control problem in the framework of Stokes' system, on a domain with rapidly oscillating boundary, are the subject matters of this article. We consider a three dimensional domain constituted of a parallelepiped with a large number of rectangular cylinders at the top of it. An interior control is applied in a proper subdomain of the parallelepiped, away from the oscillating volume. We consider two types of functionals, namely a functional involving the  $L^2$ -norm of the state variable and another one involving its  $H^1$ -norm. The asymptotic analysis of optimality systems for both cases, when the cross sectional area of the rectangular cylinders tends to zero, is done here. Our major contribution is to derive error estimates for the state, the co-state and the associated pressures, in appropriate functional spaces.*

**Keywords** Adjoint system; Error estimates; Homogenization; Interior control; Optimal control; Oscillating boundary; Stokes' system.

**Mathematics Subject Classification** 35B27; 35B40; 35B37; 49J20; 49K20.

### 1. INTRODUCTION

In this article, we consider the Stokes' system in a bounded domain in  $\mathbb{R}^3$  whose boundary is rapidly oscillating. The problems in domains with oscillatory boundaries have important applications in industry. We basically, consider a three dimensional cube (for simplicity) with, attached on one side, a large number of square pillars (see Figure 1) of length  $O(1)$ , but whose cross sectional area is of order  $\varepsilon^2$ . As  $\varepsilon \rightarrow 0$ , this gives a

Received 27 October 2012; Revised and Accepted 04 June 2013.

Address correspondence to J.-P. Raymond, Institut de Mathématiques de Toulouse, Université Paul Sabatier & CNRS, Toulouse Cedex 31062, France; E-mail: raymond@math.univ-toulouse.fr

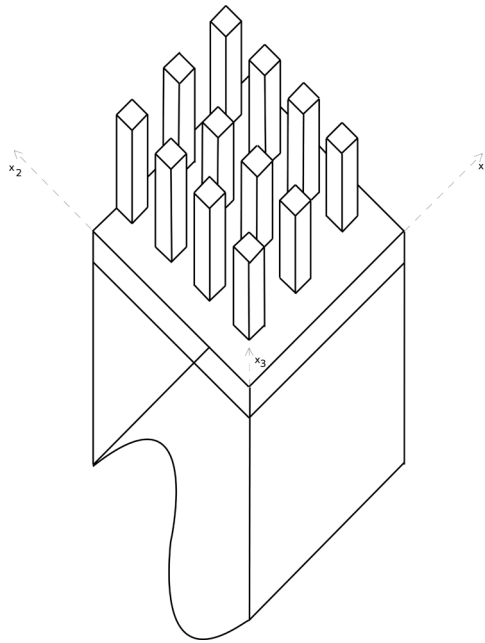

**FIGURE 1** Domain.

geometrical domain with a rapidly oscillating boundary. Our intention is to consider a distributed optimal control problem associated to a Stokes' system in such a domain and to study the relevant homogenization to obtain the limit system. Our major issue is to obtain some corrector estimates. The limit analysis of problems posed in domains with rapidly oscillating boundaries models a large number of physical applications. The authors recently studied such a homogenization problem for the Laplace operator in [34].

In particular, the applications include flows with rough boundaries, rough interface, as well as airflow through compression systems in turbo machines such as jet engine. The Viscous-Moore-Greitzer equation derived from Scaled Navier-Stokes equations (see [11, 30, 31]) models such a situation and, actually, our present and our earlier works are motivated by these issues. For a detailed analytical treatment of the Navier-Stokes equations, we refer to [21]. Quite often, such models lead to optimal control or controllability problems of evolution equations whose boundary is not only oscillatory, but moving as well. Such boundaries can be modeled via functions of both spatial and time variables. We do not attempt to do this in the article, we consider a simple problem described by the Stokes' system.

The literature on the asymptotic analysis of problems with oscillating boundaries is extensive and we refer to [1, 3, 5, 8, 12–15, 22, 23, 35], and

the references therein. But little work is available for the corresponding control problems and we refer to [17–19, 34] in that direction. We do not pretend to be exhaustive. Some standard references in homogenization theory are [10, 16, 24, 37]. Regarding the homogenization of optimal control or controllability problems, some of the references are [25, 26, 32, 33]. A few references are concerned with optimal control problems and derivation of optimality systems, one can refer to [2, 9, 14, 20, 27–29].

In this article, we study optimal control problems for models already studied in [6]. In [7], the authors derive a wall law for the model considered here and in [6]. The system associated to this wall law is used to obtain errors estimates both on the velocity and pressure in  $\Omega^-$ . Here, motivated by [4], we use suitable test functions to get error estimates for the velocity term separately in  $\Omega_\varepsilon^+$  and  $\Omega^-$ , which is not the case in [7].

This article is organized as follows. We describe the geometrical setting and the control problems we want to deal with in section 2. We introduce two types of cost functionals, namely a  $L^2$  cost functional and a Dirichlet type cost functional. The limit of the solutions for the control problem associated with the  $L^2$  cost functional, as well as correctors and asymptotic approximations, are studied in section 3. The corresponding results for the Dirichlet cost functional are derived in section 4.

## 2. SETTING OF THE PROBLEMS

### 2.1. Geometrical Domain

The purpose of this paper is to analyze the asymptotic behavior of the optimality system associated with the Stokes' system with an interior control in a varying domain  $\Omega_\varepsilon$ , where  $\varepsilon$  is a positive small parameter, tending to zero. Here we will discuss two types of cost functionals. The first one, hereafter called the  $L^2$ -cost functional, will involve the  $L^2$ -norm of the state variable and of the interior control, whereas in the second one, called the Dirichlet cost functional, we consider the  $H^1$ -norm of the state variable with the  $L^2$ -norm of the interior control.

To define the domain  $\Omega_\varepsilon$ , let us denote  $A = [0, L_1] \times [0, L_2]$  and  $\widehat{A} = [a_1, b_1] \times [a_2, b_2]$ , where  $0 < a_j < b_j < L_j$ ,  $j = 1, 2$ , are positive real numbers. For the future convenience in the conclusion of regularity results, let  $g$  be a smooth function from  $\mathbb{R}^2$  to  $\mathbb{R}$ ,  $A$ -periodic. Using  $g$ , we define the lower boundary of domain  $\Omega_\varepsilon$ , namely,

$$\Gamma_b = \{(x', x_3) \in \mathbb{R}^3 \mid x_3 = g(x'), x' \in A\}.$$

Let us set

$$m := \max\{|g(x')|, x' \in A\}.$$

Further, set  $A_\varepsilon := \varepsilon A$  and  $\widehat{A}_\varepsilon := \varepsilon \widehat{A}$ . For  $M' > M > m$ , define the  $A_\varepsilon$ -periodic function  $\eta_\varepsilon$  from  $\mathbb{R}^2$  to  $\mathbb{R}$  by

$$\eta_\varepsilon(x') = \begin{cases} M' & \text{if } x' \in \widehat{A}_\varepsilon, \\ M & \text{if } x' \in A_\varepsilon \setminus \widehat{A}_\varepsilon. \end{cases}$$

We consider the following domain (see Figure 1)  $\Omega_\varepsilon$ , as

$$\Omega_\varepsilon = \{(x', x_3) \in \mathbb{R}^3 \mid x' \in A, g(x') < x_3 < \eta_\varepsilon(x')\}.$$

The oscillating domain  $\Omega_\varepsilon$  has a fixed region  $\Omega^-$  (unaffected by the oscillating boundary), defined by

$$\Omega^- = \{(x', x_3) \mid x' \in A, g(x') < x_3 < M\}.$$

The upper and lateral boundaries  $\Gamma_u$ ,  $\Gamma_s$  of  $\Omega^-$  can be, respectively, described as

$$\Gamma_u = \{(x', M) \mid x' \in A\}$$

and

$$\Gamma_s = \{(x', x_3) \mid x' \in \partial A, g(x') \leq x_3 \leq M\},$$

where  $\partial A$  is the boundary of the reference cell  $A$ . Let us denote by  $\Omega_\varepsilon^+$  the upper oscillating part of the oscillating volume, that is,

$$\Omega_\varepsilon^+ = \{(x', x_3) \in \mathbb{R}^3 \mid x' \in A, M < x_3 < \eta_\varepsilon(x')\}.$$

Let  $\Gamma_\varepsilon$  be the interface between  $\Omega_\varepsilon^+$  and  $\Omega^-$ . Consequently, we can write

$$\Omega_\varepsilon = \Omega^- \cup \Gamma_\varepsilon \cup \Omega_\varepsilon^+.$$

Analogous to  $g$ , the graph of  $\eta_\varepsilon$  constructs the oscillating boundary part of domain  $\Omega_\varepsilon$ , namely,

$$\gamma_\varepsilon = (\partial\Omega_\varepsilon^+ \setminus \Gamma_u) \cup (\Gamma_u \setminus \partial\Omega_\varepsilon^+).$$

Notice that,  $\Omega_\varepsilon^+$  is constituted of cylindrical periodic bumps of rectangular cross-section, situated at the top of a fixed domain  $\Omega^-$ . We can also visualize  $\Omega_\varepsilon$  as a domain  $\Omega^-$  together with a large number of bumps ( $O(\varepsilon^{-2})$ ) having cross-section of order  $\varepsilon$  and fixed height ( $M' - M$ ). If we denote the boundary of  $\Omega_\varepsilon$  by  $\partial\Omega_\varepsilon$ , then we can decompose it as

$$\partial\Omega_\varepsilon = \Gamma_b \cup \Gamma_s \cup \gamma_\varepsilon.$$

Finally, we introduce the full domain  $\Omega$  as,

$$\Omega = \{(x', x_3) \in \mathbb{R}^3 \mid x' \in A, g(x') < x_3 < M'\}.$$

We denote by  $\tilde{\Omega}_\varepsilon$ , the periodic extension of  $\Omega_\varepsilon$  in the  $x_1$  and  $x_2$  directions. For this extension, we introduce the notion of  $\Gamma_s$ -periodic functions if they take same values on both sides of  $\Gamma_s$ . Moreover,  $H_{per}^m(\Omega_\varepsilon)$  is the subspace of functions which can be extended to functions belonging to  $H_{loc}^m(\mathbb{R}^3)$  and which are  $\Gamma_s$ -periodic. The same type of notation is used for other spaces, in particular for  $L^2(\Omega_\varepsilon)$ .

Let  $\omega \subset\subset \Omega^-$  be a subdomain of  $\Omega^-$  in which control acts. Without loss of generality, we assume that

$$\omega = \{(x', x_3) \mid x' \in A, g(x_1) < x_3 < M^-\},$$

where  $M > M^- > m$ .

### 2.2. Control Problems

For a control function  $\theta \in (L_{per}^2(\omega))^3$  acting in the sub-domain  $\omega$ , we consider the Stokes' system ( $\kappa > 0$ )

$$\begin{cases} -\kappa \Delta y_\varepsilon + \nabla p_\varepsilon = f + \theta \chi_\omega \text{ in } \Omega_\varepsilon, \\ \nabla \cdot y_\varepsilon = 0 \text{ in } \Omega_\varepsilon, \\ y_\varepsilon = 0 \text{ on } \gamma_\varepsilon, \quad y_\varepsilon = u \text{ on } \Gamma_b, \\ \int_{\Omega^-} p_\varepsilon = 0, \\ (y_\varepsilon, \nabla p_\varepsilon) \text{ is } \Gamma_s \text{ - periodic,} \end{cases} \tag{2.1}$$

where  $f \in (L_{per}^2(\Omega))^3$  and  $u \in (H_{per}^{1/2}(\Gamma_b))^3$  such that  $u \cdot \nu = 0$ , where  $\nu$  is the outward unit normal at  $\Gamma_b$ .

**Theorem 2.1.** *For all  $f \in (L_{per}^2(\Omega))^3$ ,  $\theta \in (L_{per}^2(\omega))^3$ , and  $u \in (H_{per}^{1/2}(\Gamma_b))^3$  satisfying  $u \cdot \nu = 0$ , Equation (2.1) admits a unique solution  $(y_\varepsilon(\theta), p_\varepsilon(\theta))$  in  $(H_{per}^1(\Omega_\varepsilon))^3 \times L_{per}^2(\Omega_\varepsilon)$ , and*

$$\|y_\varepsilon\|_{(H^1(\Omega_\varepsilon))^3} + \|p_\varepsilon\|_{L^2(\Omega^-)} \leq C \left( \|f\|_{(L^2(\Omega))^3} + \|\theta\|_{(L^2(\omega))^3} + \|u\|_{(H^{1/2}(\Gamma_b))^3} \right), \tag{2.2}$$

where  $C$  is a positive constant independent of  $\varepsilon$ , and

$$\|p_\varepsilon\|_{L^2(\Omega_\varepsilon)} \leq C_\varepsilon \left( \|f\|_{(L^2(\Omega))^3} + \|\theta\|_{(L^2(\omega))^3} + \|u\|_{(H^{1/2}(\Gamma_b))^3} \right), \tag{2.3}$$

where  $C_\varepsilon > 0$  depends on  $\varepsilon$ .

*Proof.* For  $\delta > 0$  small enough, we first introduce the subdomain

$$\Omega_\delta^- = \{(x', x_3) \mid x' \in A, g(x') < x_3 < M - \delta\},$$

and its upper and lateral boundaries  $\Gamma_{u,\delta}$  and  $\Gamma_{s,\delta}$  defined by

$$\Gamma_{u,\delta} = \{(x', M - \delta) : x' \in A\}$$

and

$$\Gamma_{s,\delta} = \{(x', x_3) : x' \in \partial A, g(x') \leq x_3 \leq M - \delta\}.$$

Next, we denote by  $y_u$  the solution to

$$\begin{cases} \nabla \cdot y_u = 0 \text{ in } \Omega_\delta^-, \\ y_u = 0 \text{ on } \Gamma_{u,\delta}, \quad y_u = u \text{ on } \Gamma_b, \\ y_u \text{ is } \Gamma_{s,\delta} \text{-periodic.} \end{cases} \tag{2.4}$$

From [21], it follows that Equation (2.4) admits a solution which satisfies

$$\|y_u\|_{(H^1(\Omega_\delta^-))^3} \leq C \|u\|_{(H^{1/2}(\Gamma_b))^3}. \tag{2.5}$$

We denote by  $\tilde{y}_u$  the extension of  $y_u$  by zero to  $\Omega_\varepsilon \setminus \Omega_\delta^-$ . We have  $\nabla \cdot \tilde{y}_u = 0$  in  $\Omega_\varepsilon$  and

$$\|\tilde{y}_u\|_{(H^1(\Omega_\varepsilon))^3} \leq C \|u\|_{(H^{1/2}(\Gamma_b))^3}. \tag{2.6}$$

We look for the solution  $(y_\varepsilon(\theta), p_\varepsilon(\theta))$  to Equation (2.1) in the form  $y_\varepsilon(\theta) = y_u + \zeta_\varepsilon(\theta)$ . The pair  $(\zeta_\varepsilon(\theta), p_\varepsilon(\theta))$  satisfies the system

$$\begin{cases} -\kappa \Delta \zeta_\varepsilon + \nabla p_\varepsilon = \kappa \Delta \tilde{y}_u + f + \theta \chi_\omega \text{ in } \Omega_\varepsilon, \\ \nabla \cdot \zeta_\varepsilon = 0 \text{ in } \Omega_\varepsilon, \\ \zeta_\varepsilon = 0 \text{ on } \gamma_\varepsilon, \quad \zeta_\varepsilon = 0 \text{ on } \Gamma_b, \\ \int_{\Omega^-} p_\varepsilon = 0, \\ (\zeta_\varepsilon, \nabla p_\varepsilon) \text{ is } \Gamma_s \text{-periodic.} \end{cases} \tag{2.7}$$

We set

$$(H^1_{per,\Gamma_b}(\Omega_\varepsilon))^3 = \{z \in (H^1_{per}(\Omega_\varepsilon))^3 \mid z|_{\Gamma_b} = 0\},$$

and we denote by  $H_{per,\Gamma_b}^{-1}(\Omega_\varepsilon)$  its dual. The source term  $\Delta\tilde{y}_u$  may be identified with an element in  $(H_{per,\Gamma_b}^{-1}(\Omega_\varepsilon))^3$  by the formula

$$\langle \Delta\tilde{y}_u, \phi \rangle = - \int_{\Omega_\varepsilon} \nabla\tilde{y}_u : \nabla\phi, \quad \text{for all } \phi \in (H_{per,\Gamma_b}^1(\Omega_\varepsilon))^3.$$

From the variational formulation of Equation (2.7), it follows that

$$\kappa \int_{\Omega_\varepsilon} |\nabla\zeta_\varepsilon|^2 = -\kappa \int_{\Omega_\varepsilon} \nabla\tilde{y}_u : \nabla\zeta_\varepsilon + \int_{\Omega_\varepsilon} (f + \chi_\omega\theta)\zeta_\varepsilon.$$

Thus, with Young's and Poincaré's inequalities, it follows that

$$\begin{aligned} \|\zeta_\varepsilon\|_{(H^1(\Omega_\varepsilon))^3} &\leq C \left( \|f\|_{(L^2(\Omega))^3} + \|\theta\|_{(L^2(\omega))^3} + \|\tilde{y}_u\|_{(H^1(\Omega_\varepsilon))^3} \right) \\ &\leq C \left( \|f\|_{(L^2(\Omega))^3} + \|\theta\|_{(L^2(\omega))^3} + \|u\|_{(H^{1/2}(\Gamma_b))^3} \right). \end{aligned} \tag{2.8}$$

This gives the following estimate for  $y_\varepsilon$

$$\|y_\varepsilon\|_{(H^1(\Omega_\varepsilon))^3} \leq C \left( \|f\|_{(L^2(\Omega))^3} + \|\theta\|_{(L^2(\omega))^3} + \|u\|_{(H^{1/2}(\Gamma_b))^3} \right),$$

where  $C$  is independent of  $\varepsilon$ .

The estimate of  $p_\varepsilon$  in  $L_{per}^2(\Omega_\varepsilon)$  may be obtained with Equation (2.7) in a classical way. But the constant in the estimate depends on the domain, and, therefore, depends on  $\varepsilon$ . Let us explain how we can obtain an estimate of  $p_\varepsilon$  in  $L_{per}^2(\Omega^-)$  independent of  $\varepsilon$ . For that, we introduce

$$\left( H_{per,\Gamma_b \cup \Gamma_u}^1(\Omega^-) \right)^3 = \{z \in (H_{per}^1(\Omega^-))^3 \mid z|_{\Gamma_b} = 0 \text{ and } z|_{\Gamma_u} = 0\},$$

and we denote by  $(H_{per,\Gamma_b \cup \Gamma_u}^{-1}(\Omega^-))^3$  the dual of  $(H_{per,\Gamma_b \cup \Gamma_u}^1(\Omega^-))^3$ . We identify the restriction of  $\Delta y_\varepsilon$  to  $\Omega^-$  as an element in  $(H_{per,\Gamma_b \cup \Gamma_u}^{-1}(\Omega_\varepsilon))^3$  in the following way

$$\langle \Delta y_\varepsilon, \phi \rangle = - \int_{\Omega^-} \nabla y_\varepsilon : \nabla\phi, \quad \text{for all } \phi \in (H_{per,\Gamma_b \cup \Gamma_u}^1(\Omega_\varepsilon))^3.$$

Since  $y_\varepsilon$  is bounded in  $(H^1(\Omega_\varepsilon))^3$  uniformly with respect to  $\varepsilon$ , it is also bounded uniformly in  $(H^1(\Omega^-))^3$ . Thus,  $\Delta y_\varepsilon|_{\Omega^-}$  is bounded in  $(H^1(\Omega^-))^3$ . From the equality

$$\nabla p_\varepsilon = f + \theta\chi_\omega + \kappa\Delta y_\varepsilon,$$



we deduce that  $\nabla p_\varepsilon|_{\Omega^-}$  is bounded in  $(H_{per,\Gamma_b \cup \Gamma_u}^{-1}(\Omega^-))^3$ , more precisely

$$\|\nabla p_\varepsilon|_{\Omega^-}\|_{(H_{per,\Gamma_b \cup \Gamma_u}^{-1}(\Omega^-))^3} \leq C \left( \|f\|_{(L^2(\Omega))^3} + \|\theta\|_{(L^2(\omega))^3} + \|u\|_{(H^{1/2}(\Gamma_b))^3} \right).$$

Estimate (2.3) may be obtained from the previous one and from the following inequality

$$\|p\|_{L_{per}^2(\Omega^-)} \leq C \|\nabla p\|_{(H_{per,\Gamma_b \cup \Gamma_u}^{-1}(\Omega^-))^3} \quad \text{for all } p \in L_{per}^2(\Omega^-) \text{ obeying } \int_{\Omega^-} p = 0.$$

This last inequality may be proved as in [36, Lemma 1.5.4]. □

We consider the following two cost functionals, for which we are going to analyze optimality issues, namely,

$$J_{1,\varepsilon}(y_\varepsilon, \theta) = \frac{1}{2} \int_{\Omega_\varepsilon} |y_\varepsilon - y_d|^2 + \frac{\beta}{2} \int_\omega |\theta|^2$$

and

$$J_{2,\varepsilon}(y_\varepsilon, \theta) = \frac{1}{2} \int_{\Omega_\varepsilon} |\nabla(y_\varepsilon - y_d)|^2 + \frac{\beta}{2} \int_\omega |\theta|^2,$$

with  $\beta > 0$ ,  $y_d$  is a given desired state. For the  $L^2$ -cost functional  $J_{1,\varepsilon}$ , we assume  $y_d \in (L_{per}^2(\Omega))^3$ , while we assume that  $y_d \in (H_{per}^1(\Omega))^3$  for the Dirichlet cost functional  $J_{2,\varepsilon}$ . Since we are going to see that  $y_\varepsilon$  is of order  $\varepsilon$ , i.e.  $O(\varepsilon)$  in the upper part  $\Omega_\varepsilon^+$ , it is reasonable to assume  $\text{supp}(y_d) \subset \overline{\Omega^-}$ . This assumption is in force throughout the article.

We now introduce the following two optimal control problems

$$\inf\{J_{1,\varepsilon}(y_\varepsilon, \theta) \mid \theta \in (L_{per}^2(\omega))^3, (y_\varepsilon, p_\varepsilon, \theta) \text{ solves (2.1)}\} \quad (P_{1,\varepsilon})$$

and

$$\inf\{J_{2,\varepsilon}(y_\varepsilon, \theta) \mid \theta \in (L_{per}^2(\omega))^3, (y_\varepsilon, p_\varepsilon, \theta) \text{ solves (2.1)}\}, \quad (P_{2,\varepsilon})$$

corresponding to cost functionals  $J_{1,\varepsilon}$  and  $J_{2,\varepsilon}$ , respectively. Our aim in this article is to study the asymptotic analysis of the optimal solution  $(\bar{y}_\varepsilon, \bar{p}_\varepsilon, \bar{\theta}_\varepsilon)$  for each of these problems.

### 3. $L^2$ -COST FUNCTIONAL

In section 3.1, we derive the optimality system for problem  $(P_{1,\varepsilon})$  and we introduce the limit system in section 3.2. The passage to the limit in the optimality system for problem  $(P_{1,\varepsilon})$ , when  $\varepsilon$  goes to zero, is carried out in section 3.3. In order to obtain correctors and asymptotic approximations, we introduce test functions in section 3.4. Precise errors estimates are obtained in section 3.5.

#### 3.1. Optimality System

By standard arguments, we can prove that, for each  $\varepsilon > 0$ , the minimization problem  $(P_{1,\varepsilon})$  has a unique minimizer  $(\bar{y}_\varepsilon, \bar{\theta}_\varepsilon) \in (H_{per}^1(\Omega_\varepsilon))^3 \times (L_{per}^2(\omega))^3$ . Let  $(\bar{y}_\varepsilon, \bar{p}_\varepsilon)$  be the solution of (2.1) when  $\theta = \bar{\theta}_\varepsilon$ . We call  $(\bar{y}_\varepsilon, \bar{p}_\varepsilon, \bar{\theta}_\varepsilon)$ , the optimal solution of  $(P_{1,\varepsilon})$ , where  $\bar{\theta}_\varepsilon$  is the optimal control,  $\bar{y}_\varepsilon$  the optimal state and  $\bar{p}_\varepsilon$  the corresponding pressure in the Stokes' system (2.1). Further, it can be characterized using the adjoint state (co-state)  $\bar{z}_\varepsilon$ , where  $\bar{z}_\varepsilon$  along with adjoint pressure  $\bar{q}_\varepsilon$  solves the adjoint problem

$$\begin{cases} -\kappa\Delta\bar{z}_\varepsilon + \nabla\bar{q}_\varepsilon = \bar{y}_\varepsilon - y_d \text{ in } \Omega_\varepsilon, \\ \nabla \cdot \bar{z}_\varepsilon = 0 \text{ in } \Omega_\varepsilon, \\ \bar{z}_\varepsilon = 0 \text{ on } \gamma_\varepsilon \cup \Gamma_b, \\ \int_{\Omega^-} \bar{q}_\varepsilon = 0, \\ (\bar{z}_\varepsilon, \nabla\bar{q}_\varepsilon) \text{ is } \Gamma_s - \text{periodic.} \end{cases} \quad (3.1)$$

Following the classical way for proving the necessary as well as sufficient conditions for optimality and for setting up the optimality system (see, e.g., [27]), one can easily establish the following theorem for  $(P_{1,\varepsilon})$ .

**Theorem 3.1.** *Let  $f \in (L_{per}^2(\Omega))^3$  and  $(\bar{y}_\varepsilon, \bar{p}_\varepsilon, \bar{\theta}_\varepsilon)$  be the optimal solution of  $(P_{1,\varepsilon})$ . Let  $(\bar{z}_\varepsilon, \bar{q}_\varepsilon) \in (H_{per}^1(\Omega_\varepsilon))^3 \times L_{per}^2(\Omega_\varepsilon)$  solves (3.1), then the optimal control is given by*

$$\bar{\theta}_\varepsilon = -\frac{1}{\beta}\bar{z}_\varepsilon\chi_\omega.$$

Conversely, assume that the pairs  $(\hat{y}_\varepsilon, \hat{z}_\varepsilon) \in (H^1_{per}(\Omega_\varepsilon))^3 \times (H^1_{per}(\Omega_\varepsilon))^3$  and  $(\hat{p}_\varepsilon, \hat{q}_\varepsilon) \in L^2_{per}(\Omega_\varepsilon) \times L^2_{per}(\Omega_\varepsilon)$  solve the optimality system

$$\begin{cases} -\kappa\Delta\hat{y}_\varepsilon + \nabla\hat{p}_\varepsilon = f - \frac{1}{\beta}\hat{z}_\varepsilon\chi_\omega \text{ in } \Omega_\varepsilon, \\ \nabla \cdot \hat{y}_\varepsilon = 0 \text{ in } \Omega_\varepsilon, \\ \hat{y}_\varepsilon = 0 \text{ on } \gamma_\varepsilon, \quad \hat{y}_\varepsilon = u \text{ on } \Gamma_b, \\ \int_{\Omega^-} \hat{p}_\varepsilon = 0, \\ (\hat{y}_\varepsilon, \nabla\hat{p}_\varepsilon) \text{ is } \Gamma_s - \text{periodic} \end{cases} \tag{3.2}$$

$$\begin{cases} -\kappa\Delta\hat{z}_\varepsilon + \nabla\hat{q}_\varepsilon = \hat{y}_\varepsilon - y_d \text{ in } \Omega_\varepsilon, \\ \nabla \cdot \hat{z}_\varepsilon = 0 \text{ in } \Omega_\varepsilon, \\ \hat{z}_\varepsilon = 0 \text{ on } \gamma_\varepsilon \cup \Gamma_b, \\ \int_{\Omega^-} \hat{q}_\varepsilon = 0, \\ (\hat{z}_\varepsilon, \nabla\hat{q}_\varepsilon) \text{ is } \Gamma_s - \text{periodic}. \end{cases} \tag{3.3}$$

Then, the triplet  $(\hat{y}_\varepsilon, \hat{p}_\varepsilon, -\frac{1}{\beta}\hat{z}_\varepsilon\chi_\omega)$  is the optimal solution to  $(P_{1,\varepsilon})$ .

### 3.2. Limit System

To introduce the limit system, we need to go through a minimization problem corresponding to the following Stokes' system in the fixed domain  $\Omega^-$ . Given  $\theta \in (L^2_{per}(\omega))^3$ , let  $(y, p) \in (H^1_{per}(\Omega^-))^3 \times L^2_{per}(\Omega^-)$  be the unique solution to

$$\begin{cases} -\kappa\Delta y + \nabla p = f + \theta\chi_\omega \text{ in } \Omega^-, \\ \nabla \cdot y = 0 \text{ in } \Omega^-, \\ y = 0 \text{ on } \Gamma_u, \quad y = u \text{ on } \Gamma_b, \\ \int_{\Omega^-} p = 0, \\ (y, \nabla p) \text{ is } \Gamma_s - \text{periodic}. \end{cases} \tag{3.4}$$

Let  $J_1$  be the cost functional defined by

$$J_1(y, \theta) = \frac{1}{2} \int_{\Omega^-} |y - y_d|^2 + \frac{\beta}{2} \int_\omega |\theta|^2. \tag{3.5}$$

The corresponding minimization problem is

$$\inf\{J_1(y, \theta) \mid \theta \in (L^2_{per}(\omega))^3, (y, p, \theta) \text{ obeys (3.4)}\}, \tag{P_1}$$

As in subsection 3.1, one can ensure the existence and uniqueness of  $(\bar{y}, \bar{\theta}) \in (H^1_{per}(\Omega^-))^3 \times (L^2_{per}(\Omega^-))^3$  as a minimizer of  $(P_1)$  and the corresponding pressure  $\bar{p} \in L^2_{per}(\Omega^-)$ . The optimal control  $\bar{\theta}$  is characterized by  $\bar{\theta} = -\frac{1}{\beta}\bar{z}$ , where  $\bar{z} \in (H^1_{per}(\Omega^-))^3, \bar{q} \in L^2_{per}(\Omega^-)$  solve

$$\begin{cases} -\kappa\Delta\bar{z} + \nabla\bar{q} = \bar{y} - y_d \text{ in } \Omega^-, \\ \nabla \cdot \bar{z} = 0 \text{ in } \Omega^-, \\ \bar{z} = 0 \text{ on } \Gamma_u \cup \Gamma_b, \\ \int_{\Omega^-} \bar{q} = 0, \\ (\bar{z}, \nabla\bar{q}) \text{ is } \Gamma_s - \text{periodic.} \end{cases} \tag{3.6}$$

Moreover, we have following result analogous to Theorem 3.1.

**Theorem 3.2.** *Let  $f \in L^2_{per}(\Omega)$  and  $(\bar{y}, \bar{p}, \bar{\theta})$  be the optimal solution of  $(P_1)$ . The optimal control is given by*

$$\bar{\theta} = -\frac{1}{\beta}\bar{z}\chi_\omega,$$

where  $(\bar{z}, \bar{q}) \in (H^1_{per}(\Omega^-))^3 \times L^2_{per}(\Omega^-)$  solves (3.1).

Conversely, assume that the pairs  $(\hat{y}, \hat{z}) \in (H^1_{per}(\Omega^-))^3 \times (H^1_{per}(\Omega^-))^3$  and  $(\hat{p}, \hat{q}) \in L^2_{per}(\Omega^-) \times L^2_{per}(\Omega^-)$  solve the optimality systems

$$\begin{cases} -\kappa\Delta\hat{y} + \nabla\hat{p} = f - \frac{1}{\beta}\hat{z}\chi_\omega \text{ in } \Omega^-, \\ \nabla \cdot \hat{y} = 0 \text{ in } \Omega^-, \\ \hat{y} = 0 \text{ on } \Gamma_u, \quad \hat{y} = u \text{ on } \Gamma_b, \\ \int_{\Omega^-} \hat{p} = 0, \\ (\hat{y}, \nabla\hat{p}) \text{ is } \Gamma_s - \text{periodic,} \end{cases} \tag{3.7}$$

$$\left\{ \begin{array}{l} -\kappa\Delta\hat{z} + \nabla\hat{q} = \hat{y} - y_d \text{ in } \Omega^-, \\ \nabla \cdot \hat{z} = 0 \text{ in } \Omega^-, \\ \hat{z} = 0 \text{ on } \Gamma_u \cup \Gamma_b, \\ \int_{\Omega^-} \hat{q} = 0, \\ (\hat{z}, \nabla\hat{q}) \text{ is } \Gamma_s - \text{periodic.} \end{array} \right. \tag{3.8}$$

Then, the triplet  $(\hat{y}, \hat{p}, -\frac{1}{\beta}\hat{z}\chi_\omega)$  is the optimal solution to  $(P_1)$ .

### 3.3. Estimates and Asymptotic Analysis

We now establish convergence results for the optimal state, co-state, pressure, adjoint pressure and optimal control corresponding to  $(P_{1,\varepsilon})$  in appropriate functional spaces.

**Theorem 3.3.** *Let  $(\bar{y}_\varepsilon, \bar{p}_\varepsilon, \bar{\theta}_\varepsilon)$  and  $(\bar{y}, \bar{p}, \bar{\theta})$  be, respectively, the optimal solution of  $(P_{1,\varepsilon})$  and  $(P_1)$ . Suppose  $(\bar{z}_\varepsilon, \bar{q}_\varepsilon)$  and  $(\bar{z}, \bar{q})$  be the co-states and adjoint pressures appeared in the discussion of problem  $(P_{1,\varepsilon})$  and  $(P_1)$ , respectively. Then*

$$\begin{aligned} \bar{y}_\varepsilon &\rightarrow \bar{y} \text{ strongly in } (H^1_{per}(\Omega))^3, \\ \bar{p}_\varepsilon &\rightarrow \bar{p} \text{ strongly in } L^2_{per}(\Omega^-), \\ \bar{\theta}_\varepsilon &\rightarrow \bar{\theta} \text{ strongly in } (H^1_{per}(\omega))^3, \\ \bar{z}_\varepsilon &\rightarrow \bar{z} \text{ strongly in } (H^1_{per}(\Omega))^3, \\ \bar{q}_\varepsilon &\rightarrow \bar{q} \text{ strongly in } L^2_{per}(\Omega^-), \end{aligned}$$

where

$$\bar{y} = \begin{cases} 0 & \text{in } \Omega^+, \\ \bar{y} & \text{in } \Omega^-, \end{cases} \quad \text{and} \quad \bar{z} = \begin{cases} 0 & \text{in } \Omega^+, \\ \bar{z} & \text{in } \Omega^-. \end{cases}$$

Moreover,

$$J_{1,\varepsilon}(\bar{y}_\varepsilon, \bar{\theta}_\varepsilon) \rightarrow J_1(\bar{y}, \bar{\theta}) \quad \text{when } \varepsilon \rightarrow 0.$$

**Note:**  $\bar{y}_\varepsilon, \bar{z}_\varepsilon$ , denote the extension by 0 of  $\bar{y}_\varepsilon, \bar{z}_\varepsilon$ , respectively, to  $\Omega$ , and thus  $(\bar{y}_\varepsilon, \bar{z}_\varepsilon) \in (H^1_{per}(\Omega))^3 \times (H^1_{per}(\Omega))^3$ .

*Proof. Step 1. Uniform estimates.* Let  $(\bar{y}_\varepsilon, \bar{p}_\varepsilon, \bar{\theta}_\varepsilon)$  be the optimal solution of  $(P_{1,\varepsilon})$ . If we denote by  $y_\varepsilon(0)$  the solution to Equation (2.1) corresponding to  $\theta = 0$  in  $\omega$ , we have

$$J_{1,\varepsilon}(\bar{y}_\varepsilon, \bar{\theta}_\varepsilon) \leq J_{1,\varepsilon}(y_\varepsilon(0), 0).$$

From Theorem 2.1, it follows that

$$\|\bar{\theta}_\varepsilon\|_{(L^2(\omega))^3} \leq \frac{2}{\beta} J_{1,\varepsilon}(y_\varepsilon(0), 0) \leq C, \tag{3.9}$$

where  $C$  is independent of  $\varepsilon$ . Still with Theorem 2.1, it follows that

$$\|\tilde{y}_\varepsilon\|_{(H^1(\Omega))^3} = \|\bar{y}_\varepsilon\|_{(H^1(\Omega_\varepsilon))^3} \leq C, \tag{3.10}$$

and

$$\|\bar{p}_\varepsilon\|_{L^2(\Omega^-)} \leq C, \tag{3.11}$$

where the different constants  $C$  are independent of  $\varepsilon$ . Applying Theorem 2.1 to the adjoint system (3.1), we obtain

$$\|\bar{z}_\varepsilon\|_{(H^1(\Omega_\varepsilon))^3} \leq C, \tag{3.12}$$

and

$$\|\bar{q}_\varepsilon\|_{L^2(\Omega^-)} \leq C, \tag{3.13}$$

with  $C > 0$  is independent of  $\varepsilon$ . From the characterization of  $\bar{\theta}_\varepsilon$  in Theorem 3.1, we get

$$\|\bar{\theta}_\varepsilon\|_{(H^1(\omega))^3} \leq C. \tag{3.14}$$

*Step 2. Passage to the limit.* With the above estimates in (3.10)–(3.14), we can deduce the existence of  $(y_0, p_0, \theta_0, z_0, q_0) \in (H^1_{per}(\Omega))^3 \times L^2_{per}(\Omega^-) \times (H^1_{per}(\omega))^3 \times (H^1_{per}(\Omega))^3 \times L^2_{per}(\Omega^-)$ , the existence of subsequences still indexed by  $\varepsilon$  to simplify the notation, and the following convergence when  $\varepsilon$  tends to zero

$$\tilde{y}_\varepsilon \rightharpoonup y_0 \quad \text{weakly in } (H^1_{per}(\Omega))^3, \tag{3.15}$$

$$\bar{p}_\varepsilon \rightharpoonup p_0 \quad \text{weakly in } L^2_{per}(\Omega^-), \tag{3.16}$$

$$\bar{\theta}_\varepsilon \rightharpoonup \theta_0 \quad \text{weakly in } \left( H_{per}^1(\omega) \right)^3, \tag{3.17}$$

$$\tilde{z}_\varepsilon \rightharpoonup z_0 \quad \text{weakly in } \left( H_{per}^1(\Omega) \right)^3, \tag{3.18}$$

$$\bar{q}_\varepsilon \rightharpoonup q_0 \quad \text{weakly in } L_{per}^2(\Omega^-). \tag{3.19}$$

With (3.17) and (3.18), the characterization of  $\bar{\theta}_\varepsilon$  gives

$$\theta_0 = -\frac{1}{\beta} z_0 \chi_\omega. \tag{3.20}$$

Let  $\chi_{\Omega_\varepsilon^+}$  be the characteristic function of  $\Omega_\varepsilon^+ \subset \Omega^+ = \Omega \setminus \overline{\Omega^-}$ , then as in other convergence of periodic oscillatory functions, we get

$$\chi_{\Omega_\varepsilon^+} \rightharpoonup K \quad \text{weakly}^* \text{ in } L^\infty(\Omega^+), \quad \text{where } K = \frac{1}{L_1 L_2} (b_1 - a_1)(b_2 - a_2). \tag{3.21}$$

By (3.15) and compact embedding theorems, we have

$$\tilde{y}_\varepsilon \rightarrow y_0 \quad \text{strongly in } \left( L_{per}^2(\Omega) \right)^3. \tag{3.22}$$

Now, according to (3.21) and (3.22), passing to the limit in the equality  $\tilde{y}_\varepsilon = \tilde{y}_\varepsilon \chi_{\Omega_\varepsilon^+}$ , we see that  $y_0 = 0$  in  $\Omega^+$  since  $K \neq 0$ . Similarly,  $z_0 = 0$  in  $\Omega^+$ . Moreover,  $z_0 = 0$  on  $\Gamma_b$ . For  $\theta = \bar{\theta}_\varepsilon$ , weak formulation of (2.1) gives us

$$\kappa \int_{\Omega^-} \nabla \bar{y}_\varepsilon \cdot \nabla \varphi - \int_{\Omega^-} \bar{p}_\varepsilon (\nabla \cdot \varphi) = \int_{\Omega^-} f \cdot \varphi + \int_{\omega} \bar{\theta}_\varepsilon \cdot \varphi$$

for all smooth function  $\varphi$  with compact support in  $\Omega^-$ . So, with (3.15), (3.16), and (3.17), we can prove that  $y_0, p_0$  and  $\theta_0$  satisfy

$$\left\{ \begin{array}{l} -\kappa \Delta y_0 + \nabla p_0 = f + \theta_0 \chi_\omega \quad \text{in } \Omega^-, \\ \nabla \cdot y_0 = 0 \quad \text{in } \Omega^-, \\ y_0 = 0 \quad \text{on } \Gamma_u, \quad y_0 = u \quad \text{on } \Gamma_b, \\ \int_{\Omega^-} p_0 = 0, \\ (y_0, \nabla p_0) \text{ is } \Gamma_s \text{ - periodic.} \end{array} \right. \tag{3.23}$$

Similarly, we can prove that  $z_0$  and  $q_0$  satisfy the system

$$\begin{cases} -\kappa\Delta z_0 + \nabla q_0 = y_0 - y_d & \text{in } \Omega^-, \\ \nabla \cdot z_0 = 0 & \text{in } \Omega^-, \\ z_0 = 0 & \text{on } \Gamma_u \cup \Gamma_b, \\ \int_{\Omega^-} q_0 = 0, \\ (z_0, \nabla q_0) \text{ is } \Gamma_s\text{-periodic.} \end{cases} \tag{3.24}$$

Since  $\theta_0 = -\frac{1}{\beta}z_0\chi_\omega$ , from the converse part of Theorem 3.2, it follows that  $(y_0, p_0, \theta_0)$  is the optimal solution to  $(P_1)$ . Thus, we get

$$y_0 = \tilde{y}, \quad p_0 = \tilde{p}, \quad z_0 = \tilde{z}, \quad \theta_0 = \tilde{\theta} \quad \text{and} \quad q_0 = \tilde{q}.$$

Further

$$J_{1,\varepsilon}(\tilde{y}_\varepsilon, \tilde{\theta}_\varepsilon) \longrightarrow J_1(\tilde{y}, \tilde{\theta}) \quad \text{when } \varepsilon \longrightarrow 0.$$

In fact, we get the strong convergence of  $\tilde{y}_\varepsilon$  in  $(H^1_{per}(\Omega))^3$ , as well as of  $\tilde{z}_\varepsilon$ , and, hence, for the control  $\tilde{\theta}_\varepsilon$ . By using  $\tilde{y}_\varepsilon$  and  $\tilde{y}$  as test functions in (2.1) and (3.4) respectively, and from the convergences stated in (3.15) and (3.17), we get

$$\begin{aligned} \lim_{\varepsilon \rightarrow 0} \kappa \int_{\Omega} \nabla \tilde{y}_\varepsilon \cdot \nabla \tilde{y}_\varepsilon &= \lim_{\varepsilon \rightarrow 0} \int_{\Omega} f \cdot \tilde{y}_\varepsilon + \int_{\omega} \tilde{\theta}_\varepsilon \cdot \tilde{y}_\varepsilon + \left\langle \frac{\partial \tilde{y}_\varepsilon}{\partial \nu}, u \right\rangle_{(H^{-1/2}(\Gamma_b))^3, (H^{1/2}(\Gamma_b))^3} \\ &= \int_{\Omega} f \cdot \tilde{y} + \int_{\omega} \tilde{\theta} \cdot \tilde{y} + \left\langle \frac{\partial \tilde{y}}{\partial \nu}, u \right\rangle_{(H^{-1/2}(\Gamma_b))^3, (H^{1/2}(\Gamma_b))^3} \\ &= \kappa \int_{\Omega} \nabla \tilde{y} \cdot \nabla \tilde{y}. \end{aligned}$$

Thus,  $\tilde{y}_\varepsilon \longrightarrow \tilde{y}$  strongly in  $(H^1_{per}(\Omega))^3$ . A similar analysis will provide the strong convergence of  $\tilde{z}_\varepsilon$  in  $(H^1_{per}(\Omega))^3$ . The strong convergences of  $\tilde{y}_\varepsilon$ ,  $\tilde{z}_\varepsilon$  in  $(H^1_{per}(\Omega))^3$  and of  $\tilde{\theta}_\varepsilon$  in  $(H^1_{per}(\omega))^3$  will give us the strong convergence of  $\tilde{p}_\varepsilon$ ,  $\tilde{q}_\varepsilon$  in  $L^2_{per}(\Omega^-)$ . Notice

$$\begin{aligned} \|\nabla \tilde{p}_\varepsilon - \nabla \tilde{p}\|_{(H^{-1}(\Omega^-))^3} &= C \|\kappa\Delta(\tilde{y}_\varepsilon - \tilde{y}) + (\tilde{\theta}_\varepsilon - \tilde{\theta})\chi_\omega\|_{(H^{-1}(\Omega^-))^3} \\ &\leq C \left( \|\tilde{y}_\varepsilon - \tilde{y}\|_{(H^1(\Omega^-))^3} + \|\tilde{\theta}_\varepsilon - \tilde{\theta}\|_{(H^1(\omega))^3} \right), \end{aligned}$$



which gives  $\nabla \bar{p}_\varepsilon \rightarrow \nabla \bar{p}$  strongly in  $(H^1(\Omega^-))^3$  and  $\bar{p}_\varepsilon \rightarrow \bar{p}$  strongly in  $L^2_{per}(\Omega^-)$ . The strong convergence of  $\bar{q}_\varepsilon$  in  $L^2_{per}(\Omega^-)$  is obtained in a similar way. The proof is complete.  $\square$

### 3.4. Test Functions and Preliminary Results

In this section, we borrow certain test functions and results from [4], [6], which will be useful in the asymptotic approximation of the optimal state variable  $\bar{y}_\varepsilon$  and the corresponding pressure  $\bar{p}_\varepsilon$  of optimal control problem  $(P_{1,\varepsilon})$ . Moreover, these test functions will also be used for the co-state variable  $\bar{z}_\varepsilon$  and the corresponding pressure  $\bar{q}_\varepsilon$  appeared in the adjoint system of optimal control problem  $(P_{1,\varepsilon})$ .

Recall the domains  $A$  and  $\hat{A}$  defined in the introduction. Let  $\Lambda^\pm$  be the domains defined by  $\Lambda^+ = \hat{A} \times (0, \infty)$  and  $\Lambda^- = A \times (-\infty, 0)$  (see Figure 2), which in some sense have to be seen as an  $1/\varepsilon$  scaling of  $\hat{A}_\varepsilon \times (M, M')$  and  $\Omega^-$  respectively, and then extended up to infinity. For  $i = 1, 2$ , consider the pairs  $(\Psi^{i,+}, \Pi^{i,+}) \in (H^1(\Lambda^+))^3 \times L^2_{loc}(\Lambda^+)$  and  $(\Psi^{i,-}, \Pi^{i,-}) \in$

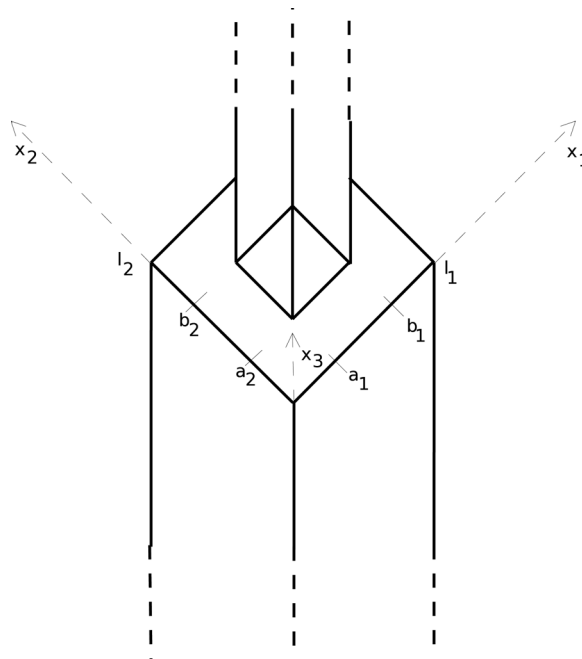

FIGURE 2 Reference domain.

$(H^1_{loc,per}(\Lambda^-))^3 \times L^2_{loc,per}(\Lambda^-)$  satisfying the following Stokes' system

$$\left\{ \begin{array}{l} -\kappa \Delta \Psi^{i,\pm} + \nabla \Pi^{i,\pm} = 0 \quad \text{in } \Lambda^\pm, \\ \nabla \cdot \Psi^{i,\pm} = 0 \quad \text{in } \Lambda^\pm, \\ \Psi^{i,+} = 0 \quad \text{on } \partial\Lambda^+ \setminus (\widehat{A} \times \{0\}), \\ \Psi^{i,-} = 0 \quad \text{on } (A \times 0) \setminus (\widehat{A} \times \{0\}), \\ \Psi^{i,+} = \Psi^{i,-} \quad \text{on } (\widehat{A} \times \{0\}), \\ \sigma(\Psi^{i,+}, \Pi^{i,+})n = \sigma(\Psi^{i,-}, \Pi^{i,-})n + \kappa e^i \quad \text{on } (\widehat{A} \times \{0\}), \\ \int_{\Lambda^\pm} \Pi^{i,\pm} dy = 0. \end{array} \right. \quad (3.25)$$

Here, we have used the following notations:  $n = (0, 0, 1)^T$ ,  $e^1 = (1, 0, 0)^T$ ,  $e^2 = (0, 1, 0)^T$ ,  $\sigma(\Psi, \Pi) = -\Pi I + \kappa(\nabla \Psi + (\nabla \Psi)^T)$ ,  $\partial\Lambda^+$  denotes the boundary of  $\Lambda^+$  and  $I$  is the  $3 \times 3$  identity matrix. It can be proved (see [4, 6]) that  $\nabla \Psi^{i,-} \in (L^2(\Lambda^-))^9$ . Also observe that, although  $\Lambda^+$  and  $\Lambda^-$  are unbounded, the last condition in (3.25) may be satisfied, since other properties in (3.25) imply that  $|\nabla \Pi^{i,\pm}(y', y_3)| \leq C \exp(-c|y_3|)$  in  $\Lambda^\pm$ , where  $C$  and  $c$  are positive constants. We denote by  $\beta^i$  the mean of  $\Psi^{i,-}$  over an horizontal section of  $\Lambda^-$ :

$$\beta^i(\delta) = \frac{1}{L_1 L_2} \int_A \Psi^{i,-}(y', -\delta) dy', \quad \delta \in (0, +\infty). \quad (3.26)$$

In [4], it is proved that  $\beta^i = (\beta_1^i, \beta_2^i, 0)$ , where  $\beta_j^i \in \mathbb{R}$  is independent of  $\delta$  for  $i, j = 1, 2$  and the solution  $(\Psi^{i,\pm}(y', y_3), \Pi^{i,\pm}(y', y_3))$  satisfy the property of exponential decay as  $y_3 \rightarrow \pm\infty$ . As an immediate consequence of this result, we have:

**Proposition 3.4.** *For  $i = 1, 2$ , let  $(\Psi^{i,+}, \Pi^{i,+})$  and  $(\Psi^{i,-}, \Pi^{i,-})$  be the solution of the problem (3.25). Then, there exists a positive constant  $C$ , independent of  $\varepsilon$ , such that*

$$\int_{\Omega_\varepsilon^+} \left| \Psi^{i,+} \left( \frac{x'}{\varepsilon}, \frac{x_3 - M}{\varepsilon} \right) \right|^2 dx + \int_{\Omega_\varepsilon^+} \left| \Pi^{i,+} \left( \frac{x'}{\varepsilon}, \frac{x_3 - M}{\varepsilon} \right) \right|^2 dx \leq C\varepsilon,$$

and

$$\int_{\Omega^-} \left| \Psi^{i,-} \left( \frac{x'}{\varepsilon}, \frac{x_3 - M}{\varepsilon} \right) - \beta^i \right|^2 dx + \int_{\Omega^-} \left| \Pi^{i,-} \left( \frac{x'}{\varepsilon}, \frac{x_3 - M}{\varepsilon} \right) \right|^2 dx \leq C\varepsilon.$$

### 3.5. Correctors and Asymptotic Approximation

In this section, we plan to derive correctors with the help of test functions introduced in section 3.4. To obtain error estimates, we need the following regularity assumptions on the data:

$$\begin{aligned} f &\in \left( H_{per}^4(\Omega^-) \right)^3 \cap \left( L_{per}^2(\Omega) \right)^3, \quad g \in H_{per}^6(A), \\ y_d &\in \left( H_{per}^4(\Omega^-) \right)^3, \quad u \in \left( H_{per}^{7/2}(\Gamma_b) \right)^3. \end{aligned} \quad (3.27)$$

**Remark 3.5.** To get error estimates on the optimal state variable  $\bar{y}_\varepsilon$  and the corresponding pressure  $\bar{p}_\varepsilon$  of optimal control problem  $(P_{1,\varepsilon})$ , one will require (3.27), though for the co-state and adjoint pressure, it is enough to have  $f \in (H_{per}^2(\Omega^-))^3 \cap (L_{per}^2(\Omega))^3$  and  $u \in (H_{per}^{7/2}(\Gamma_b))^3$ .

Let  $\mathcal{O}^-$  be defined by

$$\mathcal{O}^- = \left\{ (x', x_2) \in \mathbb{R}^3: x' \in \mathbb{R}^2, \quad g(x') < x_3 < M \right\}.$$

This is the periodically extended domain  $\Omega^-$  in the  $x_1, x_2$  directions. Let  $(\bar{z}, \bar{q})$  be extended to  $\mathcal{O}^-$  periodically, denoted again by  $(\bar{z}, \bar{q})$ . Then the pair  $(\bar{z}, \bar{q})$  solves the system

$$\begin{cases} (\bar{z}, \bar{q}) \in \left( H_{per}^1(\Omega^-) \right)^3 \times L_{per}^2(\Omega^-), \\ -\kappa \Delta \bar{z} + \nabla \bar{q} = \bar{y} - y_d \quad \text{in } \mathcal{O}^-, \\ \nabla \cdot \bar{z} = 0 \quad \text{in } \mathcal{O}^-, \\ \bar{z} = 0 \quad \text{on } \mathbb{R}^2 \times \{M\} \cup \{(x', g(x')) \in \mathbb{R}^3: x' \in \mathbb{R}^2\}. \end{cases} \quad (3.28)$$

Since the control  $\bar{\theta}$  is located in  $\omega$ , we only have  $\bar{\theta}|_{\chi_\omega} \in L^2(\omega)$ , which is a source term in (3.23). Therefore, we cannot deduce from the optimality system (3.23) and (3.24) that

$$(\bar{y}, \bar{p}) \in \left( H_{per}^6(\Omega^-) \right)^3 \times H_{per}^5(\Omega^-) \subset \left( C^4(\overline{\Omega^-}) \right)^3 \times C^3(\overline{\Omega^-}). \quad (3.29)$$

and

$$(\bar{z}, \bar{q}) \in \left( H_{per}^8(\Omega^-) \right)^3 \times H_{per}^7(\Omega^-) \subset \left( C^6(\overline{\Omega^-}) \right)^3 \times C^5(\overline{\Omega^-}). \quad (3.30)$$

We, need such a regularity for the error estimates. Fortunately, we do not need such strong smoothness in the entire domain  $\bar{\Omega}$ , it is enough to have

the regularity in a neighborhood of the upper boundary. In this direction, we define the band  $R$  as

$$R = \{(x', x_3) \mid x' \in A, \frac{M + M^-}{2} < x_3 < M\}.$$

Now, using a truncation argument, we can show that

$$(\bar{y}, \bar{p}) \in \left(H_{per}^6(R)\right)^3 \times H_{per}^5(R) \subset \left(C^4(\bar{R})\right)^3 \times C^3(\bar{R}), \tag{3.31}$$

and

$$(\bar{z}, \bar{q}) \in \left(H_{per}^8(R)\right)^3 \times H_{per}^7(R) \subset \left(C^6(\bar{R})\right)^3 \times C^5(\bar{R}), \tag{3.32}$$

since the dimension is  $n = 3$ . Let, for  $i = 1, 2$ ,

$$\Psi_\varepsilon^i(x) = \begin{cases} \Psi_\varepsilon^{i,+}(x) = \Psi^{i,+}\left(\frac{x'}{\varepsilon}, \frac{x_3 - M}{\varepsilon}\right) & \text{in } \Omega_\varepsilon^+, \\ \Psi_\varepsilon^{i,-}(x) = \Psi^{i,-}\left(\frac{x'}{\varepsilon}, \frac{x_3 - M}{\varepsilon}\right) - \beta^i & \text{in } \Omega^-, \end{cases} \tag{3.33}$$

and

$$\Pi_\varepsilon^i(x) = \begin{cases} \Pi_\varepsilon^{i,+}(x) = \Pi^{i,+}\left(\frac{x'}{\varepsilon}, \frac{x_3 - M}{\varepsilon}\right) & \text{in } \Omega_\varepsilon^+, \\ \Pi_\varepsilon^{i,-}(x) = \Pi^{i,-}\left(\frac{x'}{\varepsilon}, \frac{x_3 - M}{\varepsilon}\right) & \text{in } \Omega^-, \end{cases} \tag{3.34}$$

where  $(\Psi^{i,+}, \Pi^{i,+})$  and  $(\Psi^{i,-}, \Pi^{i,-})$  denote the solution of problem (3.25).

Now we are in a position to introduce the error estimates. We need to introduce certain test functions. Define  $B(x') = \sum_{i=1,2} \frac{\partial \bar{z}_i}{\partial x_3}(x', M)\beta^i$  for  $x' \in A$ , where  $\beta^i$  is given in (3.26), and let us denote by  $\xi_\varepsilon$  and  $\theta_\varepsilon$  the functions defined in  $\Omega_\varepsilon$  by

$$\xi_\varepsilon(x) = \begin{cases} \xi_\varepsilon^+(x) = \sum_{i=1,2} \frac{\partial \bar{z}_i}{\partial x_3}(x', M)\Psi_\varepsilon^{i,+} & \text{in } \Omega_\varepsilon^+, \\ \xi_\varepsilon^-(x) = \sum_{i=1,2} \frac{\partial \bar{z}_i}{\partial x_3}(x', M)\Psi^{i,-}\left(\frac{x'}{\varepsilon}, \frac{x_3 - M}{\varepsilon}\right) - B & \text{in } \Omega^-, \\ = \sum_{i=1,2} \frac{\partial \bar{z}_i}{\partial x_3}(x', M)\Psi_\varepsilon^{i,-} & \text{in } \Omega^-. \end{cases} \tag{3.35}$$

and

$$\theta_\varepsilon(x) = \begin{cases} \theta_\varepsilon^+(x) = \sum_{i=1,2} \frac{\partial \bar{z}_i}{\partial x_3}(x', M) \Pi_\varepsilon^{i,+} & \text{in } \Omega_\varepsilon^+, \\ \theta_\varepsilon^-(x) = \sum_{i=1,2} \frac{\partial \bar{z}_i}{\partial x_3}(x', M) \Pi_\varepsilon^{i,-} & \text{in } \Omega^-. \end{cases} \quad (3.36)$$

Using these test functions, we are now in position to derive error estimates.

**Theorem 3.6.** *Suppose the regularity assumption (3.27) holds. Let  $\bar{z}_\varepsilon$  be the optimal co-state as in (3.1) and  $\bar{q}_\varepsilon$  be the corresponding pressure. Similarly, let  $\bar{z}$  be the optimal co-state as in (3.6) and  $\bar{q}$  be the corresponding pressure. Assume  $\xi_\varepsilon$  as defined in (3.35) and  $\theta_\varepsilon$  as in (3.36). Then, there exist positive constants  $C_1, C_2$ , independent of  $\varepsilon$ , such that*

$$\|\bar{z}_\varepsilon - \varepsilon \xi_\varepsilon^+\|_{(H^1(\Omega_\varepsilon^+))^3} + \|\bar{z}_\varepsilon - \bar{z} - \varepsilon \xi_\varepsilon^-\|_{(H^1(\Omega^-))^3} \leq C_1 \left( \varepsilon + \|\bar{y}_\varepsilon - \bar{y}\|_{(L^2(\Omega^-))^3} \right)$$

and

$$\|\bar{q}_\varepsilon - \bar{q}\|_{L^2(\Omega^-)} \leq C_2 \left( \sqrt{\varepsilon} + \|\bar{y}_\varepsilon - \bar{y}\|_{(L^2(\Omega^-))^3} \right),$$

for  $\varepsilon$  small enough.

The proof of Theorem 3.6 requires another class of test functions. Let  $(\vartheta_\varepsilon^+, q_\varepsilon^+) \in (H_{per}^1(\Omega_\varepsilon^+))^3 \times L_{per}^2(\Omega_\varepsilon^+)$  and  $(\vartheta_\varepsilon^-, q_\varepsilon^-) \in (H_{per}^1(\Omega^-))^3 \times L_{per}^2(\Omega^-)$  be the solution of

$$\begin{cases} -\kappa \Delta \vartheta_\varepsilon^+ + \nabla q_\varepsilon^+ = 0 & \text{in } \Omega_\varepsilon^+, \\ -\kappa \Delta \vartheta_\varepsilon^- + \nabla q_\varepsilon^- = 0 & \text{in } \Omega^-, \\ \nabla \cdot \vartheta_\varepsilon^+ = -\nabla \cdot \xi_\varepsilon^+ & \text{in } \Omega_\varepsilon^+, \\ \nabla \cdot \vartheta_\varepsilon^- = -\nabla \cdot \xi_\varepsilon^- & \text{in } \Omega^-, \\ \vartheta_\varepsilon^+ = -\xi_\varepsilon^+ & \text{on } \gamma_\varepsilon \setminus \Gamma_u, \quad \vartheta_\varepsilon^+ = \vartheta_\varepsilon^- - B & \text{on } \Gamma_u \setminus \gamma_\varepsilon, \\ \sigma(\vartheta_\varepsilon^+, \nabla q_\varepsilon^+) n = \sigma(\vartheta_\varepsilon^-, \nabla q_\varepsilon^-) n & \text{on } \Gamma_u \setminus \gamma_\varepsilon, \\ \vartheta_\varepsilon^- = -\xi_\varepsilon^- & \text{on } \Gamma_b, \quad \vartheta_\varepsilon^- = B & \text{on } \gamma_\varepsilon \cap \Gamma_u, \\ \int_{\Omega^-} q_\varepsilon^- dx = -\frac{1}{\varepsilon} \int_{\Omega^-} \theta_\varepsilon^- dx. \end{cases} \quad (3.37)$$

Let us also introduce  $\tau_\varepsilon$  and  $\mu_\varepsilon$  defined by

$$\tau_\varepsilon(x) = \begin{cases} \tau_\varepsilon^+(x) = \bar{z}_\varepsilon - \varepsilon \vartheta_\varepsilon^+ - \varepsilon \zeta_\varepsilon^+ & \text{in } \Omega_\varepsilon^+, \\ \tau_\varepsilon^-(x) = \bar{z}_\varepsilon - \bar{z} - \varepsilon \vartheta_\varepsilon^- - \varepsilon \zeta_\varepsilon^- & \text{in } \Omega^- \end{cases} \quad (3.38)$$

and

$$\mu_\varepsilon(x) = \begin{cases} \mu_\varepsilon^+(x) = \bar{q}_\varepsilon(x) - \bar{q}(x', M) - \varepsilon q_\varepsilon^+(x) - \theta_\varepsilon^+(x) & \text{in } \Omega_\varepsilon^+, \\ \mu_\varepsilon^-(x) = \bar{q}_\varepsilon(x) - \bar{q}(x) - \varepsilon q_\varepsilon^-(x) - \theta_\varepsilon^-(x) & \text{in } \Omega^-. \end{cases} \quad (3.39)$$

Let the pair  $(\vartheta, q) \in (H_{per}^1(\Omega^-))^3 \times L_{per}^2(\Omega^-)$  solves the Stokes' system

$$\begin{cases} -\kappa \Delta \vartheta + \nabla q = 0 & \text{in } \Omega^-, \\ \nabla \cdot \vartheta = 0 & \text{in } \Omega^-, \\ \vartheta = 0 & \text{on } \Gamma_b, \quad \vartheta = B & \text{on } \Gamma_u, \\ \int_{\Omega^-} q \, dx = 0, \\ (\vartheta, \nabla q) \text{ is } \Gamma_s \text{-periodic.} \end{cases} \quad (3.40)$$

**Remark 3.7.** Observe that as in [4], it can be seen that  $B \cdot n = 0$  on  $\Gamma_u$ . Hence, the uniqueness of  $\vartheta$  is well-defined (see [36]).

Set

$$\tilde{\vartheta} = \begin{cases} 0 & \text{in } \Omega^+, \\ \vartheta & \text{in } \Omega^-, \end{cases} \quad \tilde{q} = \begin{cases} 0 & \text{in } \Omega^+, \\ q & \text{in } \Omega^-. \end{cases} \quad (3.41)$$

These test functions will be used in the error estimates and we need higher regularity results for these test functions. The regularity assumptions (3.27), with (3.31) and (3.40), provide the following regularity of  $(\vartheta, q)$

$$(\vartheta, q) \in \left( H_{per}^5(\Omega^-) \right)^3 \times H_{per}^4(\Omega^-) \subset \left( C^3(\overline{\Omega^-}) \right)^3 \times C^2(\overline{\Omega^-}). \quad (3.42)$$

Now, define the space

$$V(\Omega_\varepsilon) = \left\{ \phi \in \left( H_{per}^1(\Omega_\varepsilon^+) \right)^3 : \nabla \cdot \phi = 0 \text{ in } \Omega_\varepsilon, \quad \phi|_{\gamma_\varepsilon \cup \Gamma_b} = 0 \right\}.$$

Notice that  $(\tau_\varepsilon, \mu_\varepsilon)$  belongs to  $V(\Omega_\varepsilon) \times L^2(\Omega_\varepsilon)$ , and that normal traces of their stress tensors coincide at  $\Gamma_u \setminus \gamma_\varepsilon$ , i.e.  $\sigma(\tau_\varepsilon^+, \nabla \mu_\varepsilon^+)n = \sigma(\tau_\varepsilon^-, \nabla \mu_\varepsilon^-)n$  in  $(H^{\frac{-1}{2}}(\Gamma_u \setminus \gamma_\varepsilon))^3$ . Moreover,  $\int_{\Omega^-} \mu_\varepsilon^- dx = 0$ . For simplicity, we set

$$\vartheta_\varepsilon = \begin{cases} \vartheta_\varepsilon^+ & \text{in } \Omega_\varepsilon^+, \\ \vartheta_\varepsilon^- & \text{in } \Omega^-, \end{cases} \quad q_\varepsilon = \begin{cases} q_\varepsilon^+ & \text{in } \Omega_\varepsilon^+, \\ q_\varepsilon^- & \text{in } \Omega^-. \end{cases} \quad (3.43)$$

**Proposition 3.8.** *Suppose the regularity assumption (3.27) holds. Let  $\tau_\varepsilon$  and  $\mu_\varepsilon$  be, respectively, defined by (3.38) and (3.39). Then, there exist positive constants  $C_1, C_2$ , independent of  $\varepsilon$ , such that*

$$\begin{aligned} \|\tau_\varepsilon\|_{(H^1(\Omega_\varepsilon))^3} &\leq C_1 \left( \varepsilon^{3/2} + \|\bar{y}_\varepsilon - \bar{y}\|_{(L^2(\Omega^-))^3} \right), \\ \|\mu_\varepsilon\|_{L^2(\Omega^-)} &\leq C_2 \left( \varepsilon^{3/2} + \|\bar{y}_\varepsilon - \bar{y}\|_{(L^2(\Omega^-))^3} \right), \end{aligned}$$

for  $\varepsilon$  small enough.

*Proof.* By definition,  $(\tau_\varepsilon, \mu_\varepsilon)$  is a weak solution of the Stokes' system

$$-\kappa \Delta \tau_\varepsilon + \nabla \mu_\varepsilon = \begin{cases} \varepsilon \kappa \sum_{i=1,2} \Delta \left( \frac{\partial \bar{z}_i}{\partial x_3}(x', M) \right) \Psi_\varepsilon^{i,+} \\ + 2\varepsilon \kappa \sum_{i=1,2} \nabla \left( \frac{\partial \bar{z}_i}{\partial x_3}(x', M) \right) \nabla \Psi_\varepsilon^{i,+} \\ - \sum_{i=1,2} \nabla \left( \frac{\partial \bar{z}_i}{\partial x_3}(x', M) \Pi_\varepsilon^{i,+} \right) - \nabla (\bar{q}(x', M)) + \bar{y}_\varepsilon & \text{in } \Omega_\varepsilon^+, \\ \varepsilon \kappa \sum_{i=1,2} \Delta \left( \frac{\partial \bar{z}_i}{\partial x_3}(x', M) \right) \Psi_\varepsilon^{i,-} \\ + 2\varepsilon \kappa \sum_{i=1,2} \nabla \left( \frac{\partial \bar{z}_i}{\partial x_3}(x', M) \right) \nabla \Psi_\varepsilon^{i,-} \\ - \sum_{i=1,2} \nabla \left( \frac{\partial \bar{z}_i}{\partial x_3}(x', M) \Pi_\varepsilon^{i,-} \right) + (\bar{y}_\varepsilon - \bar{y}) & \text{in } \Omega^-. \end{cases} \quad (3.44)$$

Notice,  $\nabla \cdot \tau_\varepsilon = 0$ . Using this fact after choosing  $\tau_\varepsilon$  as a test function in (3.44) and with integration by parts, we get

$$\|\nabla\tau_\varepsilon\|_{(L^2(\Omega_\varepsilon))^9}^2 = \begin{cases} -\varepsilon\kappa \sum_{i=1,2} \int_{\Omega_\varepsilon^+} \Delta \left( \frac{\partial \bar{z}_i}{\partial x_3}(x', M) \right) \Psi_\varepsilon^{i,+} \cdot \tau_\varepsilon \\ -2\varepsilon\kappa \sum_{i=1,2} \int_{\Omega_\varepsilon^+} \left( \nabla \left( \frac{\partial \bar{z}_i}{\partial x_3}(x', M) \right) \nabla\tau_\varepsilon \right) \cdot \Psi_\varepsilon^{i,+} \\ + \int_{\Omega_\varepsilon^+} \bar{y}_\varepsilon \cdot \tau_\varepsilon \\ -\varepsilon\kappa \sum_{i=1,2} \int_{\Omega^-} \Delta \left( \frac{\partial \bar{z}_i}{\partial x_3}(x', M) \right) \Psi_\varepsilon^{i,-} \cdot \tau_\varepsilon \\ -2\varepsilon\kappa \sum_{i=1,2} \int_{\Omega^-} \left( \nabla \left( \frac{\partial \bar{z}_i}{\partial x_3}(x', M) \right) \nabla\tau_\varepsilon \right) \cdot \Psi_\varepsilon^{i,-} \\ + \int_{\Omega^-} (\bar{y}_\varepsilon - \bar{y}) \cdot \tau_\varepsilon. \end{cases} \tag{3.45}$$

Using the regularity of  $\bar{z}$  mentioned in (3.31), the Cauchy-Schwarz inequality and Proposition 3.4, one can easily prove

$$\left| \varepsilon\kappa \sum_{i=1,2} \int_{\Omega_\varepsilon^+} \Delta \left( \frac{\partial \bar{z}_i}{\partial x_3}(x', M) \right) \Psi_\varepsilon^{i,+} \cdot \tau_\varepsilon \right| \tag{3.46}$$

$$\left| -2\varepsilon\kappa \sum_{i=1,2} \int_{\Omega_\varepsilon^+} \Delta \left( \frac{\partial \bar{z}_i}{\partial x_3}(x', M) \right) \Psi_\varepsilon^{i,+} \cdot \tau_\varepsilon \right| \leq C\varepsilon^{3/2} \|\tau_\varepsilon\|_{(L^2(\Omega_\varepsilon^+))^3},$$

$$\left| \varepsilon\kappa \sum_{i=1,2} \int_{\Omega^-} \Delta \left( \frac{\partial \bar{z}_i}{\partial x_3}(x', M) \right) \Psi_\varepsilon^{i,-} \cdot \tau_\varepsilon \right| \tag{3.47}$$

$$\left| -2\varepsilon\kappa \sum_{i=1,2} \int_{\Omega^-} \Delta \left( \frac{\partial \bar{z}_i}{\partial x_3}(x', M) \right) \Psi_\varepsilon^{i,-} \cdot \tau_\varepsilon \right| \leq C\varepsilon^{3/2} \|\tau_\varepsilon\|_{(L^2(\Omega^-))^3},$$

$$\left| -2\varepsilon\kappa \sum_{i=1,2} \int_{\Omega_\varepsilon^+} \left( \nabla \left( \frac{\partial \bar{z}_i}{\partial x_3}(x', M) \right) \nabla\tau_\varepsilon \right) \cdot \Psi_\varepsilon^{i,+} \right| \leq C\varepsilon^{3/2} \|\nabla\tau_\varepsilon\|_{(L^2(\Omega_\varepsilon^+))^9} \tag{3.48}$$

and

$$\left| -2\varepsilon\kappa \sum_{i=1,2} \int_{\Omega^-} \left( \nabla \left( \frac{\partial \bar{z}_i}{\partial x_3}(x', M) \right) \nabla\tau_\varepsilon \right) \cdot \Psi_\varepsilon^{i,-} \right| \leq C\varepsilon^{3/2} \|\nabla\tau_\varepsilon\|_{(L^2(\Omega^-))^9}. \tag{3.49}$$



By the Cauchy-Schwarz inequality, we also have

$$\left| \int_{\Omega_\varepsilon^+} \bar{y}_\varepsilon \tau_\varepsilon \right| \leq C \|\bar{y}_\varepsilon\|_{(L^2(\Omega_\varepsilon^+))^3} \|\tau_\varepsilon\|_{(L^2(\Omega_\varepsilon^+))^3} \tag{3.50}$$

and

$$\left| \int_{\Omega^-} (\bar{y}_\varepsilon - \bar{y}) \tau_\varepsilon \right| \leq C \|\bar{y}_\varepsilon - \bar{y}\|_{(L^2(\Omega^-))^3} \|\tau_\varepsilon\|_{(L^2(\Omega^-))^3}. \tag{3.51}$$

Notice that  $\Omega_\varepsilon^+$  consists of  $\varepsilon$ -strips of fixed height. Applying Poincaré inequality in each strip, by summing up, we have

$$\|\tau_\varepsilon\|_{(L^2(\Omega_\varepsilon^+))^3} \leq C\varepsilon \|\nabla \tau_\varepsilon\|_{(L^2(\Omega_\varepsilon^+))^9}. \tag{3.52}$$

Considering  $y_\varepsilon$  in each strip and using Poincaré’s inequality, we obtain

$$\varepsilon \|y_\varepsilon\|_{(L^2(\Omega_\varepsilon^+))^3} \leq C\varepsilon^2. \tag{3.53}$$

In other words, the Poincaré constant is of order  $\varepsilon$  (see [5], [34]). Combining (3.45)–(3.53), we get

$$\|\nabla \tau_\varepsilon\|_{(L^2(\Omega_\varepsilon))^9} \leq C \left[ \|\bar{y}_\varepsilon - \bar{y}\|_{(L^2(\Omega^-))^3} + \varepsilon^{3/2} \right], \tag{3.54}$$

which, by Poincaré inequality, provides that

$$\|\tau_\varepsilon\|_{(H^1(\Omega_\varepsilon))^3} \leq C \left( \varepsilon^{3/2} + \|\bar{y}_\varepsilon - \bar{y}\|_{(L^2(\Omega^-))^3} \right), \tag{3.55}$$

where  $C$  a positive appropriate constant independent of  $\varepsilon$ .

For the domain  $\Omega^-$ , we now use a test function in the system (3.44) as  $\phi_\varepsilon \in (H_0^1(\Omega^-))^3$  satisfying such that  $\nabla \cdot \phi_\varepsilon = \mu_\varepsilon$  in  $\Omega^-$  and  $\|\phi_\varepsilon\|_{(H^1(\Omega^-))^3} \leq C\|\mu_\varepsilon\|_{L^2(\Omega^-)}$ , where  $C > 0$  is a constant independent of  $\varepsilon$ , we get

$$\|\mu_\varepsilon\|_{L^2(\Omega^-)}^2 = \begin{cases} \varepsilon\kappa \sum_{i=1,2} \int_{\Omega^-} \Delta \left( \frac{\partial \bar{z}_i}{\partial x_3}(x', M) \right) \Psi_\varepsilon^{i,-} \cdot \phi_\varepsilon \\ -2\varepsilon\kappa \sum_{i=1,2} \int_{\Omega^-} \Delta \left( \frac{\partial \bar{z}_i}{\partial x_3}(x', M) \right) \Psi_\varepsilon^{i,-} \cdot \phi_\varepsilon \\ -2\varepsilon\kappa \sum_{i=1,2} \int_{\Omega^-} \left( \nabla \left( \frac{\partial \bar{z}_i}{\partial x_3}(x', M) \right) \nabla \phi_\varepsilon \right) \cdot \Psi_\varepsilon^{i,-} \\ -\kappa \int_{\Omega^-} \nabla \tau_\varepsilon \cdot \nabla \phi_\varepsilon + \int_{\Omega^-} (\bar{y}_\varepsilon - \bar{y}) \cdot \phi_\varepsilon. \end{cases} \tag{3.56}$$

Using the regularity of  $\bar{z}$  mentioned in (3.31), the Cauchy-Schwarz inequality and Proposition 3.4, one can easily prove that

$$\begin{aligned} & \left| \varepsilon \kappa \sum_{i=1,2} \int_{\Omega^-} \Delta \left( \frac{\partial \bar{z}_i}{\partial x_3}(x', M) \right) \Psi_\varepsilon^{i,-} \cdot \phi_\varepsilon \right. \\ & \left. - 2\varepsilon \kappa \sum_{i=1,2} \int_{\Omega^-} \Delta \left( \frac{\partial \bar{z}_i}{\partial x_3}(x', M) \right) \Psi_\varepsilon^{i,-} \cdot \phi_\varepsilon \right| \leq C \varepsilon^{3/2} \|\phi_\varepsilon\|_{(L^2(\Omega^-))^3}, \end{aligned} \tag{3.57}$$

and

$$\left| -2\varepsilon \kappa \sum_{i=1,2} \int_{\Omega^-} \left( \nabla \left( \frac{\partial \bar{z}_i}{\partial x_3}(x', M) \right) \nabla \phi_\varepsilon \right) \cdot \Psi_\varepsilon^{i,-} \right| \leq C \varepsilon^{3/2} \|\nabla \phi_\varepsilon\|_{(L^2(\Omega^-))^9}. \tag{3.58}$$

With the Cauchy-Schwarz inequality, we also have

$$\left| -\kappa \int_{\Omega^-} \nabla \tau_\varepsilon \cdot \nabla \phi_\varepsilon \right| \leq C \|\nabla \tau_\varepsilon\|_{(L^2(\Omega^-))^9} \|\nabla \phi_\varepsilon\|_{(L^2(\Omega^-))^9} \tag{3.59}$$

and

$$\left| \int_{\Omega^-} (\bar{y}_\varepsilon - \bar{y}) \phi_\varepsilon \right| \leq C \|\bar{y}_\varepsilon - \bar{y}\|_{(L^2(\Omega^-))^3} \|\phi_\varepsilon\|_{(L^2(\Omega^-))^3}. \tag{3.60}$$

Combining (3.54), (3.56), and (3.60), we get our desired result

$$\|\mu_\varepsilon\|_{L^2(\Omega_\varepsilon)} \leq C \left[ \|\bar{y}_\varepsilon - \bar{y}\|_{(L^2(\Omega^-))^3} + \varepsilon^{3/2} \right], \tag{3.61}$$

where again  $C$  a positive appropriate constant independent of  $\varepsilon$ . □

We will borrow the following proposition from [6].

**Proposition 3.9.** *Assume that the regularity assumption (3.27) holds true. Let  $\vartheta_\varepsilon$ ,  $q_\varepsilon$  be the functions defined in (3.43), and let  $\tilde{\vartheta}$ ,  $\tilde{q}$  be defined in (3.41). Then, there exists a positive constant  $C$ , independent of  $\varepsilon$ , such that*

$$\|\vartheta_\varepsilon - \tilde{\vartheta}\|_{(H^1(\Omega_\varepsilon))^3} + \sqrt{\varepsilon} \|q_\varepsilon - \tilde{q}\|_{L^2(\Omega^-)} \leq C,$$

for  $\varepsilon$  small enough.

*Proof of Theorem 3.6.* Notice that

$$\begin{cases} \bar{z}_\varepsilon - \tilde{z} - \varepsilon \tilde{\vartheta} - \varepsilon \zeta_\varepsilon = \tau_\varepsilon + \varepsilon (\vartheta_\varepsilon - \tilde{\vartheta}) & \text{in } \Omega_\varepsilon, \\ \bar{q}_\varepsilon - \bar{q} - \varepsilon q - \theta_\varepsilon^- = \mu_\varepsilon + \varepsilon (q_\varepsilon - q) & \text{in } \Omega^-. \end{cases} \quad (3.62)$$

With Propositions 3.8 and 3.9, for  $\varepsilon$  small enough, we can prove that

$$\begin{cases} \|\bar{z}_\varepsilon - \tilde{z} - \varepsilon \tilde{\vartheta} - \varepsilon \zeta_\varepsilon\|_{(H^1(\Omega_\varepsilon))^3} \leq C_1 (\varepsilon + \|\bar{y}_\varepsilon - \bar{y}\|_{(L^2(\Omega^-))^3}), \\ \|\bar{q}_\varepsilon - \bar{q} - \varepsilon q - \theta_\varepsilon^-\|_{L^2(\Omega^-)} \leq C_2 (\sqrt{\varepsilon} + \|\bar{y}_\varepsilon - \bar{y}\|_{(L^2(\Omega^-))^3}), \end{cases} \quad (3.63)$$

where  $C_1, C_2$  are positive constants, independent of  $\varepsilon$ . But

$$\begin{aligned} & \|\bar{z}_\varepsilon - \varepsilon \zeta_\varepsilon^+\|_{(H^1(\Omega_\varepsilon^+))^3} + \|\bar{z}_\varepsilon - \bar{z} - \varepsilon \zeta_\varepsilon^-\|_{(H^1(\Omega^-))^3} \\ & \leq \|\bar{z}_\varepsilon - \varepsilon \zeta_\varepsilon^+\|_{(H^1(\Omega_\varepsilon^+))^3} + \|\bar{z}_\varepsilon - \bar{z} - \varepsilon \tilde{\vartheta} - \varepsilon \zeta_\varepsilon^-\|_{(H^1(\Omega^-))^3} + \|\varepsilon \tilde{\vartheta}\|_{(H^1(\Omega^-))^3} \\ & = \|\bar{z}_\varepsilon - \tilde{z} - \varepsilon \tilde{\vartheta} - \varepsilon \zeta_\varepsilon^-\|_{(H^1(\Omega_\varepsilon))^3} + \varepsilon \|\tilde{\vartheta}\|_{(H^1(\Omega^-))^3} \end{aligned} \quad (3.64)$$

and

$$\begin{aligned} & \|\bar{q}_\varepsilon - \bar{q}\|_{L^2(\Omega^-)} \\ & \leq \|\bar{q}_\varepsilon - \bar{q} - \varepsilon q - \theta_\varepsilon^-\|_{L^2(\Omega^-)} + \|\varepsilon q + \theta_\varepsilon^-\|_{L^2(\Omega^-)} \\ & = \|\bar{q}_\varepsilon - \bar{q} - \varepsilon q - \theta_\varepsilon^-\|_{L^2(\Omega^-)} + \varepsilon \|q\|_{L^2(\Omega^-)} + \|\theta_\varepsilon^-\|_{L^2(\Omega^-)}. \end{aligned} \quad (3.65)$$

Again notice that  $\|\theta_\varepsilon^-\|_{L^2(\Omega^-)}$  is of order  $\sqrt{\varepsilon}$ . Consequently, the proof of the theorem follows immediately from (3.63), (3.64), and (3.65).  $\square$

To derive similar estimates for the optimal state variable  $\bar{y}_\varepsilon$  and the corresponding pressure  $\bar{p}_\varepsilon$  of optimal control problem  $(P_{1,\varepsilon})$ , we need to define  $\hat{B}(x') = \sum_{i=1,2} \frac{\partial \bar{y}_i}{\partial x_3}(x', M) \beta^i$ , for  $x' \in A$ , where  $\beta^i$  is same as in (3.26).

Let us denote the function  $\hat{\zeta}_\varepsilon$ , defined in  $\Omega_\varepsilon$  by

$$\hat{\zeta}_\varepsilon(x) = \begin{cases} \hat{\zeta}_\varepsilon^+(x) = \sum_{i=1,2} \frac{\partial \bar{y}_i}{\partial x_3}(x', M) \Psi^{i,+} \left( \frac{x'}{\varepsilon}, \frac{x_3 - M}{\varepsilon} \right) & \text{in } \Omega_\varepsilon^+, \\ \hat{\zeta}_\varepsilon^-(x) = \sum_{i=1,2} \frac{\partial \bar{y}_i}{\partial x_3}(x', M) \Psi^{i,-} \left( \frac{x'}{\varepsilon}, \frac{x_3 - M}{\varepsilon} \right) - \hat{B} & \text{in } \Omega^-, \end{cases} \quad (3.66)$$

where  $\bar{y}_\varepsilon$  is the optimal state variable corresponding to the optimal control problem  $(P_1)$ , and where, for  $i=1,2$ ,  $(\Psi^{i,+})$  and  $(\Psi^{i,-})$  are defined as the solution to problem (3.25). Finally, with the same type of proof as done for Theorem 3.6, we have the following theorem.

**Theorem 3.10.** *Suppose that the regularity assumption (3.27) holds true. Let  $\bar{y}_\varepsilon$  be the optimal state variable and  $\bar{p}_\varepsilon$  be the corresponding pressure for the optimal control problem  $(P_{1,\varepsilon})$ . Again let  $\bar{y}$  be the optimal state and  $\bar{p}$  be the corresponding pressure for the limit optimal control problem  $(P_1)$ . Then, there exist positive constants  $C_1, C_2$ , independent of  $\varepsilon$ , such that*

$$\|\bar{y}_\varepsilon - \varepsilon \hat{\xi}_\varepsilon^+\|_{(H^1(\Omega_\varepsilon))^3} + \|\bar{y}_\varepsilon - \bar{y} - \varepsilon \hat{\xi}_\varepsilon^-\|_{(H^1(\Omega_\varepsilon))^3} \leq C_1 \left( \varepsilon + \|\bar{z}_\varepsilon - \bar{z}\|_{(L^2(\omega))^3} \right),$$

and

$$\|\bar{p}_\varepsilon - \bar{p}\|_{L^2(\Omega^-)} \leq C_2 \left( \sqrt{\varepsilon} + \|\bar{z}_\varepsilon - \bar{z}\|_{(L^2(\omega))^3} \right),$$

for  $\varepsilon$  small enough, where  $\hat{\xi}_\varepsilon$  is the function defined in (3.66).

#### 4. DIRICHLET COST FUNCTIONAL

In this section, we will focus on the minimization problem  $(P_{2,\varepsilon})$  which is regarding the optimality of Dirichlet cost functional. We will first see the optimality condition as well as optimality system corresponding to  $(P_{2,\varepsilon})$ . After that, with the help of appropriate estimates we will observe the asymptotic behavior of the optimal solution, co-state, adjoint pressure and optimal control of the problem  $(P_{2,\varepsilon})$ . We will conclude this section by stating results related to asymptotic approximation.

For each  $\varepsilon \downarrow 0$ , the minimization problem  $(P_{2,\varepsilon})$  has a unique minimizer  $(\bar{y}_\varepsilon, \bar{\theta}_\varepsilon) \in (H^1_{per}(\Omega_\varepsilon))^3 \times (L^2_{per}(\omega))^3$ . The corresponding pressure in the Stokes' system (2.1) is denoted by  $\bar{p}_\varepsilon$ , and we will say that  $(\bar{y}_\varepsilon, \bar{p}_\varepsilon, \bar{\theta}_\varepsilon)$  is the optimal solution of  $(P_{2,\varepsilon})$ . Further, it can be characterized using the adjoint state (co-state)  $\bar{z}_\varepsilon$ , where  $\bar{z}_\varepsilon$ , along with adjoint pressure  $\bar{q}_\varepsilon$ , solves the adjoint problem

$$\begin{cases} -\kappa \Delta \bar{z}_\varepsilon + \nabla \bar{q}_\varepsilon = -\Delta (\bar{y}_\varepsilon - y_d) & \text{in } \Omega_\varepsilon, \\ \nabla \cdot \bar{z}_\varepsilon = 0, & \text{in } \Omega_\varepsilon, \\ \bar{z}_\varepsilon = 0, & \text{on } \gamma_\varepsilon \cup \Gamma_b, \\ \int_{\Omega^-} \bar{q}_\varepsilon = 0, \\ (\bar{z}_\varepsilon, \nabla \bar{q}_\varepsilon) \text{ is } \Gamma_s - \text{periodic.} \end{cases} \tag{4.1}$$

As in the  $L^2$ -cost functional case, we have the following optimality conditions for  $(P_{2,\varepsilon})$ .

**Theorem 4.1.** *Let  $f$  belong to  $(L^2_{per}(\Omega))^3$  and let  $(\bar{y}_\varepsilon, \bar{p}_\varepsilon, \bar{\theta}_\varepsilon)$  be the optimal solution of  $(P_{2,\varepsilon})$ . Let  $(\bar{z}_\varepsilon, \bar{q}_\varepsilon) \in (H^1_{per}(\Omega_\varepsilon))^3 \times L^2_{per}(\Omega_\varepsilon)$  be the solution of (4.1). Then the optimal control is given by*

$$\bar{\theta}_\varepsilon = -\frac{1}{\beta} \bar{z}_\varepsilon \chi_\omega.$$

*Conversely, assume that the pairs  $(\hat{y}_\varepsilon, \hat{z}_\varepsilon) \in (H^1_{per}(\Omega_\varepsilon))^3 \times (H^1_{per}(\Omega_\varepsilon))^3$  and  $(\hat{p}_\varepsilon, \hat{q}_\varepsilon) \in L^2_{per}(\Omega_\varepsilon) \times L^2_{per}(\Omega_\varepsilon)$  solve the optimality system*

$$\begin{cases} -\kappa \Delta \hat{y}_\varepsilon + \nabla \hat{p}_\varepsilon = f - \frac{1}{\beta} \hat{z}_\varepsilon \chi_\omega & \text{in } \Omega_\varepsilon, \\ \nabla \cdot \hat{y}_\varepsilon = 0 & \text{in } \Omega_\varepsilon, \\ \hat{y}_\varepsilon = 0 & \text{on } \gamma_\varepsilon, \quad \hat{y}_\varepsilon = u & \text{on } \Gamma_b, \\ \int_{\Omega^-} \hat{p}_\varepsilon = 0, \\ (\hat{y}_\varepsilon, \nabla \hat{p}_\varepsilon) & \text{is } \Gamma_s\text{-periodic.} \end{cases} \tag{4.2}$$

$$\begin{cases} -\kappa \Delta \hat{z}_\varepsilon + \nabla \hat{q}_\varepsilon = -\Delta (\hat{y}_\varepsilon - y_d) & \text{in } \Omega_\varepsilon, \\ \nabla \cdot \hat{z}_\varepsilon = 0 & \text{in } \Omega_\varepsilon, \\ \hat{z}_\varepsilon = 0 & \text{on } \gamma_\varepsilon \cup \Gamma_b, \\ \int_{\Omega^-} \hat{q}_\varepsilon = 0. \\ (\hat{z}_\varepsilon, \nabla \hat{q}_\varepsilon) & \text{is } \Gamma_s\text{-periodic.} \end{cases} \tag{4.3}$$

*Then, the triplet  $(\hat{y}_\varepsilon, \hat{p}_\varepsilon, -\frac{1}{\beta} \hat{z}_\varepsilon \chi_\omega)$  is the optimal solution to  $(P_{2,\varepsilon})$ .*

Following a procedure similar to that in section 3.3, we have following estimate

$$\|\bar{y}_\varepsilon\|_{(H^1(\Omega_\varepsilon))^3} + \|\bar{p}_\varepsilon\|_{L^2(\Omega^-)} + \|\bar{z}_\varepsilon\|_{(H^1(\Omega_\varepsilon))^3} + \|\bar{\theta}_\varepsilon\|_{(H^1(\omega))^3} + \|\bar{q}_\varepsilon\|_{L^2(\Omega^-)} \leq C, \tag{4.4}$$

where  $C > 0$  is independent of  $\varepsilon$ . As for Theorem 3.3, we can prove the following theorem.

**Theorem 4.2.** *Let  $(\bar{y}_\varepsilon, \bar{p}_\varepsilon, \bar{\theta}_\varepsilon)$  be the optimal solution of  $(P_{2,\varepsilon})$  then*

$$\bar{y}_\varepsilon \rightarrow \bar{y} \text{ strongly in } (H^1_{per}(\Omega))^3,$$

$$\begin{aligned} \bar{p}_\varepsilon &\rightarrow \bar{p} \quad \text{strongly in } L^2_{per}(\Omega^-), \\ \bar{\theta}_\varepsilon &\rightarrow \bar{\theta} \quad \text{strongly in } (H^1_{per}(\omega))^3, \\ \bar{z}_\varepsilon &\rightarrow \bar{z} \quad \text{strongly in } (H^1_{per}(\Omega))^3, \\ \bar{q}_\varepsilon &\rightarrow \bar{q} \quad \text{strongly in } L^2_{per}(\Omega^-). \end{aligned}$$

where

$$\bar{y} = \begin{cases} 0 & \text{in } \Omega^+, \\ \bar{y} & \text{in } \Omega^-, \end{cases} \quad \bar{z} = \begin{cases} 0 & \text{in } \Omega^+, \\ \bar{z} & \text{in } \Omega^-, \end{cases}$$

$\bar{y}, \bar{z} \in (H^1_{per}(\Omega^-))^3$ , along with  $\bar{p}, \bar{q} \in L^2_{per}(\Omega^-)$ , solves the system

$$\begin{cases} -\kappa\Delta\bar{y} + \nabla\bar{p} = f - \frac{1}{\beta}\bar{z}\chi_\omega & \text{in } \Omega^-, \\ \nabla \cdot \bar{y} = 0 & \text{in } \Omega^-, \\ \bar{y} = 0 \quad \text{on } \Gamma_u, \quad \bar{y} = u, & \text{on } \Gamma_b, \\ \int_{\Omega^-} \bar{p} = 0, \\ (\bar{y}, \nabla\bar{p}) \text{ is } \Gamma_s\text{-periodic,} \end{cases} \tag{4.5}$$

$$\begin{cases} -\kappa\Delta\bar{z} + \nabla\bar{q} = -\Delta(\bar{y} - y_d) & \text{in } \Omega^-, \\ \nabla \cdot \bar{z} = 0 & \text{in } \Omega^-, \\ \bar{z} = 0 & \text{on } \Gamma_u \cup \Gamma_b, \\ \int_{\Omega^-} \bar{q} = 0, \\ (\bar{z}, \nabla\bar{q}) \text{ is } \Gamma_s\text{-periodic,} \end{cases} \tag{4.6}$$

and  $\bar{\theta} = -\frac{1}{\beta}\bar{z}\chi_\omega$ . Moreover,

$$J_{2,\varepsilon}(\bar{y}_\varepsilon, \bar{\theta}_\varepsilon) \rightarrow J_2(\bar{y}, \bar{\theta}) \quad \text{when } \varepsilon \rightarrow 0,$$

where

$$J_2(y, \theta) = \frac{1}{2} \int_{\Omega^-} |\nabla(y - y_d)|^2 + \frac{\beta}{2} \int_\omega |\theta|^2. \tag{4.7}$$

If we consider the minimization problem for cost functional  $J_2$  as

$$\inf\{J_2(y, \theta) \mid \theta \in \left(L^2_{per}(\omega)\right)^3, (y, p, \theta) \text{ obeys (3.4)}\}, \tag{P_2}$$

then by our next theorem, the above mentioned pair  $(\bar{y}, \bar{\theta}) \in \left(H^1_{per}(\Omega^-)\right)^3 \times \left(H^1_{per}(\omega)\right)^3$  is the unique solution of  $(P_2)$ .

**Theorem 4.3.** *Let  $f \in L^2_{per}(\Omega)$  and  $(\bar{y}, \bar{p}, \bar{\theta})$  be the optimal solution of  $(P_2)$ . Let  $(\bar{z}, \bar{q}) \in \left(H^1_{per}(\Omega^-)\right)^3 \times L^2_{per}(\Omega^-)$  solves (4.6), then the optimal control is given by*

$$\bar{\theta} = -\frac{1}{\beta} \bar{z} \chi_\omega.$$

Conversely, assume that the pairs  $(\hat{y}, \hat{z}) \in \left(H^1_{per}(\Omega^-)\right)^3 \times \left(H^1_{per}(\Omega^-)\right)^3$  and  $(\hat{p}, \hat{q}) \in L^2_{per}(\Omega^-) \times L^2_{per}(\Omega^-)$  solve the optimality system

$$\begin{cases} -\kappa \Delta \hat{y} + \nabla \hat{p} = f - \frac{1}{\beta} \hat{z} \chi_\omega & \text{in } \Omega_\varepsilon, \\ \nabla \cdot \hat{y} = 0 & \text{in } \Omega^-, \\ \hat{y} = 0 & \text{on } \Gamma_u, \quad \hat{y} = u & \text{on } \Gamma_b, \\ \int_{\Omega^-} \hat{p} = 0, \\ (\hat{y}, \nabla \hat{p}) & \text{is } \Gamma_s\text{-periodic,} \end{cases} \tag{4.8}$$

and

$$\begin{cases} -\kappa \Delta \hat{z} + \nabla \hat{q} = -\Delta(\hat{y} - y_d) & \text{in } \Omega^-, \\ \nabla \cdot \hat{z} = 0, & \text{in } \Omega^-, \\ \hat{z} = 0 & \text{on } \Gamma_u \cup \Gamma_b, \\ \int_{\Omega^-} \hat{q} = 0, \\ (\hat{z}, \nabla \hat{q}) & \text{is } \Gamma_s\text{-periodic.} \end{cases} \tag{4.9}$$

Then, the triplet  $(\hat{y}, \hat{p}, -\frac{1}{\beta} \hat{z} \chi_\omega)$  is the optimal solution to  $(P_2)$ .

Define  $\check{B}(x') = \sum_{i=1,2} \frac{\partial \bar{y}_i}{\partial x_3}(x', M)\beta^i$ , for  $x' \in A$ , where  $\beta^i$  is defined in (3.26), and let us denote by  $\check{\zeta}_\varepsilon$  the function defined in  $\Omega_\varepsilon$  by

$$\check{\zeta}_\varepsilon(x) = \begin{cases} \check{\zeta}_\varepsilon^+(x) = \sum_{i=1,2} \frac{\partial \bar{y}_i}{\partial x_3}(x', M)\Psi^{i,+}\left(\frac{x'}{\varepsilon}, \frac{x_3 - M}{\varepsilon}\right) & \text{in } \Omega_\varepsilon^+, \\ \check{\zeta}_\varepsilon^-(x) = \sum_{i=1,2} \frac{\partial \bar{y}_i}{\partial x_3}(x', M)\Psi^{i,-}\left(\frac{x'}{\varepsilon}, \frac{x_3 - M}{\varepsilon}\right) - \check{B} & \text{in } \Omega^-, \end{cases} \tag{4.10}$$

where  $\bar{y}$  is the optimal state variable corresponding to the optimal control problem  $(P_2)$  and where, for  $i = 1, 2$ ,  $(\Psi^{i,+})$  and  $(\Psi^{i,-})$  are the solution to problem (3.25). We will have the following theorem, whose proof can be derived as in the case of the  $L^2$ -cost functional.

**Theorem 4.4.** *Suppose that the regularity assumption (3.27) holds true. Let  $\bar{y}_\varepsilon$  be the optimal state variable of optimal control problem  $(P_{2,\varepsilon})$ , and  $\bar{p}_\varepsilon$  be the corresponding pressure. Again let  $\bar{y}$  be of optimal control problem  $(P_2)$ , and let  $\bar{p}$  be the corresponding pressure. Then, for  $\varepsilon$  small enough, there exist positive constants  $C_1, C_2$ , independent of  $\varepsilon$ , such that*

$$\|\bar{y}_\varepsilon - \varepsilon \check{\zeta}_\varepsilon^+\|_{(H^1(\Omega_\varepsilon^+))^3} + \|\bar{y}_\varepsilon - \bar{y} - \varepsilon \check{\zeta}_\varepsilon^-\|_{(H^1(\Omega^-))^3} \leq C_1 \left( \varepsilon + \|\bar{z}_\varepsilon - \bar{z}\|_{(L^2(\omega))^3} \right),$$

and

$$\|\bar{p}_\varepsilon - \bar{p}\|_{L^2(\Omega^-)} \leq C_2 \left( \sqrt{\varepsilon} + \|\bar{z}_\varepsilon - \bar{z}\|_{(L^2(\omega))^3} \right),$$

for  $\varepsilon$  small enough, where  $\check{\zeta}_\varepsilon$  is defined in (4.10).

Define  $\check{B}(x') = \sum_{i=1,2} \frac{\partial \bar{z}_i}{\partial x_3}(x', M)\beta^i$ , for  $x' \in A$ , and let us denote by  $\check{\zeta}_\varepsilon$ , the function

$$\check{\zeta}_\varepsilon(x) = \begin{cases} \check{\zeta}_\varepsilon^+(x) = \sum_{i=1,2} \frac{\partial \bar{z}_i}{\partial x_3}(x', M)\Psi^{i,+}\left(\frac{x'}{\varepsilon}, \frac{x_3 - M}{\varepsilon}\right) & \text{in } \Omega_\varepsilon^+, \\ \check{\zeta}_\varepsilon^-(x) = \sum_{i=1,2} \frac{\partial \bar{z}_i}{\partial x_3}(x', M)\Psi^{i,-}\left(\frac{x'}{\varepsilon}, \frac{x_3 - M}{\varepsilon}\right) - \check{B} & \text{in } \Omega^-, \end{cases} \tag{4.11}$$

where  $\bar{z}$  is the co-state variable corresponding to the optimal control problem  $(P_2)$ , and where, for  $i = 1, 2$ ,  $(\Psi^{i,+})$  and  $(\Psi^{i,-})$  are the solutions to problem (3.25). As in the case of the  $L^2$ -cost functional, we have the following theorem.



**Theorem 4.5.** *Suppose that the regularity assumption (3.27) holds true. Let  $\bar{z}_\varepsilon$  be the co-state variable and  $\bar{q}_\varepsilon$  the corresponding pressure for the optimal control problem  $(P_{2,\varepsilon})$ . Again let  $\bar{z}$  be the co-state variable and  $\bar{q}$  the corresponding pressure for the optimal control problem  $(P_2)$ . Then there exist positive constants  $C_1, C_2$ , independent of  $\varepsilon$ , such that*

$$\|\bar{z}_\varepsilon - \varepsilon \check{\xi}_\varepsilon^+\|_{(H^1(\Omega_\varepsilon^+))^3} + \|\bar{z}_\varepsilon - \bar{z} - \varepsilon \check{\xi}_\varepsilon^-\|_{(H^1(\Omega^-))^3} \leq C_1 \left( \varepsilon + \|\bar{y}_\varepsilon - \bar{y}\|_{(H^1(\Omega^-))^3} \right),$$

and

$$\|\bar{p}_\varepsilon - \bar{p}\|_{L^2(\Omega^-)} \leq C_2 \left( \sqrt{\varepsilon} + \|\bar{y}_\varepsilon - \bar{y}\|_{(H^1(\Omega^-))^3} \right),$$

for  $\varepsilon$  small enough, where  $\check{\xi}_\varepsilon$  is defined in (4.11).

## ACKNOWLEDGMENTS

A. K. Nandakumaran and R. Prakash would like to thank UGC for the support to the Center for Advanced Studies (CAS), Department of Mathematics, IISc.

## REFERENCES

1. Y. Achdou, O. Pironneau, and F. Valentin (1998). Effective boundary conditions for laminar flows over periodic rough boundaries. *J. Comput. Phys.* 147:187–218.
2. G. Allaire and M. Amar (1999). Boundary layer tails in periodic homogenization. *ESAIM Control Optim. Calc. Var.* 4:209–243 (electronic).
3. Y. Amirat and O. Bodart (2001). Boundary layer correctors for the solution of Laplace equation in a domain with oscillating boundary. *Z. Anal. Anwendungen* 20:929–940.
4. Y. Amirat and O. Bodart (2010). Stokes equations with interface condition in an unbounded domain. *Appl. Anal.* 89:29–47.
5. Y. Amirat, O. Bodart, U. De Maio, and A. Gaudiello (2004). Asymptotic approximation of the solution of the Laplace equation in a domain with highly oscillating boundary. *SIAM J. Math. Anal.* 35(6):1598–1616 (electronic).
6. Y. Amirat, O. Bodart, U. De Maio, and A. Gaudiello (2007). Asymptotic approximation of the solution of Stokes equations in a domain with highly oscillating boundary. *Ann. Univ. Ferrara Sez. VII Sci. Mat.* 53:135–148.
7. Y. Amirat, O. Bodart, U. De Maio, and A. Gaudiello (2013). Effective boundary condition for Stokes flow over a very rough surface. *Journal of Differential Equations* 254:3395–3430.
8. J. M. Arrieta and S. M. Bruschi (2007). Rapidly varying boundaries in equations with nonlinear boundary conditions. The case of a Lipschitz deformation. *Math. Models Methods Appl. Sci.* 17:1555–1585.
9. V. Barbu (1994). *Mathematical Methods in Optimization of Differential Systems*, Vol. 310, Mathematics and its Applications. Kluwer Academic Publishers Group, Dordrecht, 1994. Translated and revised from the 1989 Romanian original.
10. A. Bensoussan, J.-L. Lions, and G. Papanicolaou (1978). *Asymptotic Analysis for Periodic Structures*. North Holland, Amsterdam.
11. B. Birnir, S. Hou, and N. Wellander (2007). Derivation of the viscous Moore-Greitzer equation for aeroengine flow. *J. Math. Phys.* 48:065209,31.
12. D. Blanchard, L. Carbone, and A. Gaudiello (1999). Homogenization of a monotone problem in a domain with oscillating boundary. *Mathematical Modelling and Numerical Analysis* 33:1057–70.

13. J. F. Bonder, R. Orive, and J. D. Rossi (2007). The best Sobolev trace constant in a domain with oscillating boundary. *Nonlinear Anal.* 67:1173–1180.
14. R. Brizzi and J.-P. Chalot (1998/1997). Boundary homogenization and Neumann boundary value problem. *Ricerche Mat.* 46:341–387.
15. D. Bucur, E. Feireisl, Šárka Nečasová, and J. Wolf (2008). On the asymptotic limit of the Navier-Stokes system on domains with rough boundaries. *J. Differential Equations* 244:2890–2908.
16. D. Cioranescu and P. Donato (1999). *An Introduction to Homogenization*. Oxford University Press.
17. C. D'Apice, U. De Maio, and P. I. Kogut (2008). Gap phenomenon in the homogenization of parabolic optimal control problems. *IMA Journal of Mathematical Control and Information* 5: 461–489.
18. U. De Maio, A. Gaudiello, and A. Lefter (2004). Optimal control for a parabolic problem in a domain with highly oscillating boundary. *Applicable Analysis* 83:1245–1264.
19. T. Durante, L. Faella, and C. Perugia (2007). Homogenization and behaviour of optimal controls for the wave equation in domains with oscillating boundary. *NoDEA* 14:455–489.
20. A. V. Fursikov (2000). *Optimal Control of Distributed Systems. Theory and Applications*, Vol. 187, Translations of Mathematical Monographs. American Mathematical Society, Providence, RI, 2000. Translated from the 1999 Russian original by Tamara Rozhkovskaya.
21. G. P. Galdi (1994). *An Introduction to the Mathematical Theory of the Navier-Stokes Equations. Vol. I*, Vol. 38, Springer Tracts in Natural Philosophy. Springer-Verlag, New York. Linearized steady problems.
22. A. Gaudiello (1994). Asymptotic behaviour of non-homogeneous Neumann problems in domains with oscillating boundary. *Ricerche Mat.* 43(2):239–292.
23. A. Gaudiello, R. Hadji, and C. Picard (2003). Homogenization of the Ginzburg-Landau equation in a domain with oscillating boundary. *Commun. Appl. Anal.* 7:209–223.
24. V. V. Jikov, S. M. Kozlov, and O. A. Oleĭnik (1994). *Homogenization of Differential Operators and Integral Functionals*. Springer-Verlag, Berlin.
25. S. Kesavan and J. Saint Jean Paulin (1997). Homogenization of an optimal control problem. *SIAM J. Control Optim.* 35:1557–1573.
26. S. Kesavan and J. Saint Jean Paulin (1999). Optimal control on perforated domains. *J. Math. Anal. Appl.* 229:563–586.
27. J.-L. Lions (1971). *Optimal Control of Systems Governed by Partial Differential Equations*. Translated from the French by S. K. Mitter. Die Grundlehren der mathematischen Wissenschaften, Band 170. Springer-Verlag, New York.
28. J.-L. Lions (1988). *Contrôlabilité exacte, perturbations et stabilisation de systèmes distribués. Tome 1*, Vol. 8, Recherches en Mathématiques Appliquées [Research in Applied Mathematics]. Masson, Paris. Contrôlabilité exacte. [Exact controllability], With appendices by E. Zuazua, C. Bardos, G. Lebeau and J. Rauch.
29. J.-L. Lions (1988). *Contrôlabilité exacte, perturbations et stabilisation de systèmes distribués. Tome 2*, *Recherches en Mathématiques Appliquées [Research in Applied Mathematics]*. Vol. 9, Masson, Paris. Perturbations. [Perturbations].
30. F. K. Moore and E. M. Greitzer (1986). A theory of post-stall transients in axial compression systems: Part 1 development of equations. *Trans. ASME: J. Eng. Gas Turbines Power* 108:68–76.
31. F. K. Moore and E. M. Greitzer (1986). A theory of post-stall transients in axial compression systems: Part 2 application. *Trans. ASME: J. Eng. Gas Turbines Power* 108:231–239.
32. T. Muthukumar and A. K. Nandakumaran (2008). Darcy-type law associated to an optimal control problem. *Electron. J. Differential Equations* 16(12).
33. T. Muthukumar and A. K. Nandakumaran (2009). Homogenization of low-cost control problems on perforated domains. *J. Math. Anal. Appl.* 351:29–42.
34. A. K. Nandakumaran, R. Prakash, and J.-P. Raymond (2012). Asymptotic analysis and error estimates for an optimal control problem with oscillating boundaries. *Ann. Univ. Ferrara Sez. VII Sci. Mat.* 58:143–166.
35. N. Neuss, M. Neuss-Radu, and A. Mikelić (2006). Effective laws for the Poisson equation on domains with curved oscillating boundaries. *Appl. Anal.* 85:479–502.
36. H. Sohr (2001). *The Navier-Stokes Equations: An Elementary Functional Analytic Approach*. Birkhäuser advanced texts, Birkhäuser, Boston, Basel, Berlin.
37. L. Tartar (2009). *The General Theory of Homogenization*, Vol. 7, Lecture Notes of the Unione Matematica Italiana. Springer-Verlag, Berlin. A personalized introduction.